



DU PAGE COUNTY

Public Works Committee

Regular Meeting Agenda

421 N. COUNTY FARM ROAD
WHEATON, IL 60187
www.dupagecounty.gov

Tuesday, July 7, 2026

9:00 AM

Room 3500B

1. **CALL TO ORDER**

2. **ROLL CALL**

3. **CHAIRMAN'S REMARKS - CHAIR CHILDRESS**

4. **PUBLIC COMMENT**

5. **APPROVAL OF MINUTES**

5.A. [26-1912](#)

Public Works Committee - Regular Meeting Minutes - Tuesday, June 16, 2026

6. **BUDGET TRANSFERS**

6.A. [26-1913](#)

Facilities Management - Transfer of funds from account number 6000-1220-54010 (Building Improvements) in the amount of \$52,385 to 6000-1220-54107 (Software) for the Metasys Server Software upgrade for Facilities Management.

7. **CONSENT ITEMS**

7.A. [26-1914](#)

Public Works - CDM Smith, 4094SERV - This Purchase Order is decreasing in the amount of \$11,997.33 and closing due to contract has expired.

7.B. [26-1915](#)

Public Works - Dynamic Industrial Services, Inc., 7804SERV - This Purchase Order is decreasing in the amount of \$45,850 and closing due to contract has expired.

7.C. [26-1916](#)

Public Works - Commonwealth Edison Company, 7076SERV - This Purchase Order is decreasing in the amount of \$223,430.29 and closing due to contract has expired.

7.D. [26-1917](#)

Public Works - Mansfield Power and Gas, LLC., 5449SERV - This Purchase Order is decreasing in the amount of \$292,441.15 and closing due to contract has expired.

8. JOINT PURCHASING AGREEMENT**8.A. [FM-P-0021-26](#)**

Recommendation for the approval of a contract to Johnson Controls Building Solutions LLC, to upgrade the existing Metasys Server Software, for Facilities Management, for the period of July 14, 2026 through July 13, 2027, for a total contract amount not to exceed \$52,385. Contract pursuant to the Intergovernmental Cooperation Act (Sourcewell Contract #080824-JHN).

9. BID AWARD**9.A. [PW-P-0013-26](#)**

Recommendation for the approval of a contract purchase order to Tyler Technologies, Inc., for the Tyler Munis Cloud Based Customer Information/Utility Billing System Software as a Service (SaaS), for the period of October 1, 2026 to September 30, 2028, for a total contract amount not to exceed \$150,000. Contract pursuant to the Intergovernmental Cooperation Act (Sourcewell Contract #060624-TTI).

9.B. [FM-P-0022-26](#)

Recommendation for the approval of a contract to Malcor Roofing of Illinois, Inc., for roof restoration work at the Sheriff's Office, for Facilities Management, for the period of July 14, 2026 through July 13, 2027, for a total contract amount not to exceed \$548,784.50. Contract pursuant to the Intergovernmental Cooperation Act (Omnia Contract #R230404).

9.C. [FM-P-0023-26](#)

Recommendation for the approval of a contract to Design Developers & Rehub, Inc., for the DuPage County Historical Museum front entrance stairs replacement, for Facilities Management, for the period of July 14, 2026 through July 13, 2027, for a contract total amount not to exceed \$287,100; per bid #26-011-FM.

9.D. [PW-P-0019-26](#)

Recommendation for the approval of a contract to One2One Communications d/b/a OneSource, for utility bill printing and mailing services, for Public Works, for the period of August 1, 2026 to July 31, 2030, for a total contract amount not to exceed \$75,000; per RFP #26-015-PW.

10. ACTION ITEMS**10.A. [PW-R-0006-26](#)**

Resolution to Rescind PW-P-0015-26 issued to Peregrine Services, Inc. to provide Utility Bill Printing and Mailing Services for Public Works (Contract total not to exceed \$88,300.80).

11. INFORMATIONAL**11.A. [26-1918](#)**

Facilities request from St. Isaac Jogues Parish.

- 12. OLD BUSINESS**
- 13. NEW BUSINESS**
- 14. ADJOURNMENT**



Minutes

421 N. COUNTY FARM
ROAD
WHEATON, IL 60187
www.dupagecounty.gov

File #: 26-1912

Agenda Date: 7/7/2026

Agenda #: 5.A.



DU PAGE COUNTY

Public Works Committee

Final Summary

421 N. COUNTY FARM ROAD
WHEATON, IL 60187
www.dupagecounty.gov

Tuesday, June 16, 2026

9:00 AM

Room 3500B

1. CALL TO ORDER

9:00 AM meeting was called to order by Chair Michael Childress at 9:00 AM.

2. ROLL CALL

Member Dawn DeSart arrived at 9:02 am due to attending another committee meeting.

Other board members present:

Member Cindy Cahill, Member Yeena Yoo, Member Saba Haider

PRESENT	Childress, Deacon Garcia, Ozog, and Zay
REMOTE	Galassi
LATE	DeSart

MOTION TO ALLOW REMOTE PARTICIPATION

Member Ozog moved and Member Deacon Garcia seconded a motion to allow Member Galassi to conduct the meeting via teleconference/remotely.

RESULT:	APPROVED
MOVER:	Mary Ozog
SECONDER:	Paula Deacon Garcia

3. CHAIRMAN'S REMARKS - CHAIR CHILDRESS

No remarks were offered.

4. PUBLIC COMMENT

No public comments were offered.

5. APPROVAL OF MINUTES

5.A. [26-1707](#)

Public Works Committee - Regular Meeting Minutes - Tuesday, June 2, 2026

RESULT:	APPROVED
MOVER:	Jim Zay

SECONDER: Mary Ozog

6. BID AWARD

6.A. [26-1708](#)

Recommendation for the approval of a contract to Hawkins, Inc., for chemicals, chemical parts and supplies on an as needed basis, for Public Works, for the period of June 16, 2026 to June 15, 2027, for a total contract amount not to exceed \$ 20,000; per bid #26-035-PW.

RESULT: APPROVED
MOVER: Michael Childress
SECONDER: Paula Deacon Garcia

7. BID RENEWAL

7.A. [PW-P-0017-26](#)

Recommendation for the approval of a contract to Sheffield Safety and Loss Company, LLC, to provide Safety Program Management for various County Departments, for the period of June 25, 2026 to June 24, 2027, for a total contract amount not to exceed \$150,000; per RFP #25-046-PW. First of three options to renew.

RESULT: APPROVED AND SENT TO FINANCE
MOVER: Michael Childress
SECONDER: Paula Deacon Garcia

7.B. [PW-P-0018-26](#)

Recommendation for the approval of a contract to Mid American Water, for Waterous Pacer Hydrants, for the period of June 26, 2026 to June 25, 2027, for a total contract amount not to exceed \$62,500; per bid #24-078-PW. Second of three options to renew.

RESULT: APPROVED AND SENT TO FINANCE
MOVER: Michael Childress
SECONDER: Jim Zay

8. INFORMATIONAL

8.A. [26-1709](#)

Memorial Park Dedication Ceremony, June 16, 2026, at 12:30 P.M.

Chief Administrative Officer Nick Kottmeyer reminded the Public Works Committee that the Memorial Park dedication is at 12:30 pm on the 16th of June.

RESULT:	ACCEPTED AND PLACED ON FILE
MOVER:	Michael Childress
SECONDER:	Paula Deacon Garcia

8.B. [26-1710](#)

Public Works 2025 Audit Financial Result Review

Chief Administrative Officer Nick Kottmeyer, Financial Administrator Stan Spera, and Joe Lightcap reviewed the Public Works Audit Financial Results for 2025. Joe Lightcap from Bakertilly reviewed the audit process and issued a clean/unmodified review of The System. Mr. Kottmeyer, Mr. Spera, and Mr. Lightcap answered any questions.

RESULT:	ACCEPTED AND PLACED ON FILE
MOVER:	Michael Childress
SECONDER:	Dawn DeSart

9. OLD BUSINESS

No old business was discussed.

10. NEW BUSINESS

No new business was discussed.

11. ADJOURNMENT

With no further business, the meeting was adjourned.



Budget Transfer

421 N. COUNTY FARM
ROAD
WHEATON, IL 60187
www.dupagecounty.gov

File #: 26-1913

Agenda Date: 7/7/2026

Agenda #: 6.A.

DuPage County, Illinois
 BUDGET ADJUSTMENT
 Effective April 1, 2026

From: 6000
 Company #

FAC MGMT CTY INFRASTRUCTURE
 From: Company/Accounting Unit Name

Accounting Unit	Account	Sub-Account	Title	Amount	Finance Dept Use Only Available Balance		Date of Balance
					Prior to Transfer	After Transfer	
1220	54010		BUILDING IMPROVEMENTS	\$ 52,385.00	11,034,704.47	10,982,372.47	6/25/26
Total				\$ 52,385.00			

To: 6000
 Company #

FAC MGMT CTY INFRASTRUCTURE
 To: Company/Accounting Unit Name

Accounting Unit	Account	Sub-Account	Title	Amount	Finance Dept Use Only Available Balance		Date of Balance
					Prior to Transfer	After Transfer	
1220	54107		SOFTWARE	\$ 52,385.00	Ø	52,385.00	6/25/26
Total				\$ 52,385.00			

Reason for Request:

Budget transfer needed for the Metasys Server upgrade for the Power Plant for Facilities Management.

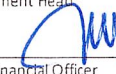
 Department Head 6/25/26
 Date

 Chief Financial Officer 6/24/26
 Date

Activity _____
 (optional)

****Please sign in blue ink on the original form****

Finance Department Use Only

Fiscal Year 26 Budget Journal # _____ Acctg Period _____

Entered By/Date _____ Released & Posted By/Date _____

PW - 7/7/26
 FIN/CB - 7/14/26



Consent Item

421 N. COUNTY FARM
ROAD
WHEATON, IL 60187
www.dupagecounty.gov

File #: 26-1914

Agenda Date: 7/7/2026

Agenda #: 7.A.

Consent
PW 717
CB 714



Request for Change Order
Procurement Services Division
 Attach copies of all prior Change Orders

Date: Jun 12, 2026

MinuteTraq (IQM2) ID #: NA

Purchase Order #: 4094SERV	Original Purchase Order Date: Sep 1, 2019	Change Order #: 14	Department: Public Works
Vendor Name: CDM SMITH INC.		Vendor #: 13295	Dept Contact: Drew J. Cormican
Background and/or Reason for Change Order Request:	Decrease contract by 11,997.33 and close contract		
IN ACCORDANCE WITH 720 ILCS 5/33E-9			

- (A) Were not reasonably foreseeable at the time the contract was signed.
- (B) The change is germane to the original contract as signed.
- (C) Is in the best interest for the County of DuPage and authorized by law.

INCREASE/DECREASE		
A	Starting contract value	\$2,184,415.00
B	Net \$ change for previous Change Orders	
C	Current contract amount (A + B)	\$2,184,415.00
D	Amount of this Change Order <input type="checkbox"/> Increase <input checked="" type="checkbox"/> Decrease	(\$11,997.33)
E	New contract amount (C + D)	\$2,172,417.67
F	Percent of current contract value this Change Order represents (D / C)	-0.55%
G	Cumulative percent of all Change Orders (B+D/A); (60% maximum on construction contracts)	-0.55%

DECISION MEMO NOT REQUIRED

Cancel entire order
 Close Contract
 Contract Extension (29 days)
 Consent Only

Change budget code from: _____ to: _____

Increase/Decrease quantity from: _____ to: _____

Price shows: _____ should be: _____

Decrease remaining encumbrance and close contract
 Increase encumbrance and close contract
 Decrease encumbrance
 Increase encumbrance

DECISION MEMO REQUIRED

Increase (greater than 29 days) contract expiration from: _____ to: _____

Increase ≥ \$2,500.00, or ≥ 10%, of current contract amount Funding Source _____

OTHER - explain below: _____

<u>Dse</u>		<u>6/17/26</u>	<u>m</u>		<u>6/11/26</u>
Prepared By (Initials)	Phone Ext	Date	Recommended for Approval (Initials)	Phone Ext	Date
REVIEWED BY (Initials Only)					
			<u>[Signature]</u>		<u>7/1/2026</u>
Buyer		Date	Procurement Officer		Date
Chief Financial Officer (Decision Memos Over \$25,000)		Date	Chairman's Office (Decision Memos Over \$25,000)		Date



Consent Item

421 N. COUNTY FARM
ROAD
WHEATON, IL 60187
www.dupagecounty.gov

File #: 26-1915

Agenda Date: 7/7/2026

Agenda #: 7.B.

Consent
PW 717
OB 7114



Request for Change Order
Procurement Services Division
Attach copies of all prior Change Orders

Date: Jun 12, 2026

MinuteTraq (IQM2) ID #: NA

Purchase Order #: 7804SERV	Original Purchase Order Date: Jul 8, 2025	Change Order #: 1	Department: Public Works
Vendor Name: Dynamic Industrial Services Inc.		Vendor #: 33093	Dept Contact: Drew J. Cormican
Background and/or Reason for Change Order Request:	Decrease contract by 45,850 and close contract		
IN ACCORDANCE WITH 720 ILCS 5/33E-9			

- (A) Were not reasonably foreseeable at the time the contract was signed.
- (B) The change is germane to the original contract as signed.
- (C) Is in the best interest for the County of DuPage and authorized by law.

INCREASE/DECREASE		
A	Starting contract value	\$390,600.00
B	Net \$ change for previous Change Orders	
C	Current contract amount (A + B)	\$390,600.00
D	Amount of this Change Order <input type="checkbox"/> Increase <input checked="" type="checkbox"/> Decrease	(\$45,850.00)
E	New contract amount (C + D)	\$344,750.00
F	Percent of current contract value this Change Order represents (D / C)	-11.74%
G	Cumulative percent of all Change Orders (B+D/A): (60% maximum on construction contracts)	-11.74%

DECISION MEMO NOT REQUIRED

Cancel entire order
 Close Contract
 Contract Extension (29 days)
 Consent Only

Change budget code from: _____ to: _____

Increase/Decrease quantity from: _____ to: _____

Price shows: _____ should be: _____

Decrease remaining encumbrance and close contract
 Increase encumbrance and close contract
 Decrease encumbrance
 Increase encumbrance

DECISION MEMO REQUIRED

Increase (greater than 29 days) contract expiration from: _____ to: _____

Increase ≥ \$2,500.00, or ≥ 10%, of current contract amount
 Funding Source _____

OTHER - explain below: _____

<u>DJE</u>		<u>6/17/26</u>	<u>MC</u>		<u>6/18/26</u>
Prepared By (Initials)	Phone Ext	Date	Recommended for Approval (Initials)	Phone Ext	Date
REVIEWED BY (Initials Only)					
			<u>8</u>		<u>7/1/2026</u>
Buyer		Date	Procurement Officer		Date
Chief Financial Officer (Decision Memos Over \$25,000)		Date	Chairman's Office (Decision Memos Over \$25,000)		Date



Consent Item

421 N. COUNTY FARM
ROAD
WHEATON, IL 60187
www.dupagecounty.gov

File #: 26-1916

Agenda Date: 7/7/2026

Agenda #: 7.C.

Consent
PW 717
OB 7114



Request for Change Order

Procurement Services Division

Attach copies of all prior Change Orders

Date: Jun 12, 2026

MinuteTraq (IQM2) ID #: NA

Purchase Order #: 7076SERV	Original Purchase Order Date: Jun 8, 2024	Change Order #: 1	Department: Public Works
Vendor Name: Commonwealth Edison Company		Vendor #: 10023	Dept Contact: Drew J. Cormican
Background and/or Reason for Change Order Request:	Decrease contract by 223,430.29 and close contract		
IN ACCORDANCE WITH 720 ILCS 5/33E-9			

- (A) Were not reasonably foreseeable at the time the contract was signed.
- (B) The change is germane to the original contract as signed.
- (C) Is in the best interest for the County of DuPage and authorized by law.

INCREASE/DECREASE		
A	Starting contract value	\$1,300,000.00
B	Net \$ change for previous Change Orders	
C	Current contract amount (A + B)	\$1,300,000.00
D	Amount of this Change Order <input type="checkbox"/> Increase <input checked="" type="checkbox"/> Decrease	(\$223,430.29)
E	New contract amount (C + D)	\$1,076,569.71
F	Percent of current contract value this Change Order represents (D / C)	-17.19%
G	Cumulative percent of all Change Orders (B+D/A); (60% maximum on construction contracts)	-17.19%

DECISION MEMO NOT REQUIRED

Cancel entire order
 Close Contract
 Contract Extension (29 days)
 Consent Only

Change budget code from: _____ to: _____

Increase/Decrease quantity from: _____ to: _____

Price shows: _____ should be: _____

Decrease remaining encumbrance and close contract
 Increase encumbrance and close contract
 Decrease encumbrance
 Increase encumbrance

DECISION MEMO REQUIRED

Increase (greater than 29 days) contract expiration from: _____ to: _____

Increase ≥ \$2,500.00, or ≥ 10%, of current contract amount Funding Source _____

OTHER - explain below: _____

<u>bse</u>		<u>6/17/26</u>	<u>M</u>		<u>6/11/26</u>
Prepared By (Initials)	Phone Ext	Date	Recommended for Approval (Initials)	Phone Ext	Date
REVIEWED BY (Initials Only)					
			<u>[Signature]</u>		<u>7/1/2026</u>
Buyer		Date	Procurement Officer		Date
Chief Financial Officer (Decision Memos Over \$25,000)		Date	Chairman's Office (Decision Memos Over \$25,000)		Date



Consent Item

421 N. COUNTY FARM
ROAD
WHEATON, IL 60187
www.dupagecounty.gov

File #: 26-1917

Agenda Date: 7/7/2026

Agenda #: 7.D.

Consent
PW 7/7
CB 7/14



Request for Change Order
Procurement Services Division

Attach copies of all prior Change Orders

Date: Jun 17, 2026

MinuteTraq (IQM2) ID #: NA

Purchase Order #: 5449SERV	Original Purchase Order Date: Oct 1, 2021	Change Order #: 1	Department: Public Works
Vendor Name: Mansfield Power and Gas, LLC		Vendor #: 27225	Dept Contact: Drew J. Cormican

Background and/or Reason for Change Order Request: Decrease contract by 292,441.15 and close contract

IN ACCORDANCE WITH 720 ILCS 5/33E-9

- (A) Were not reasonably foreseeable at the time the contract was signed.
- (B) The change is germane to the original contract as signed.
- (C) Is in the best interest for the County of DuPage and authorized by law.

INCREASE/DECREASE		
A	Starting contract value	\$650,000.00
B	Net \$ change for previous Change Orders	
C	Current contract amount (A + B)	\$650,000.00
D	Amount of this Change Order <input type="checkbox"/> Increase <input checked="" type="checkbox"/> Decrease	(\$292,441.15)
E	New contract amount (C + D)	\$357,558.85
F	Percent of current contract value this Change Order represents (D / C)	-44.99%
G	Cumulative percent of all Change Orders (B+D/A); (60% maximum on construction contracts)	-44.99%

DECISION MEMO NOT REQUIRED

- Cancel entire order
- Close Contract
- Contract Extension (29 days)
- Consent Only
- Change budget code from: _____ to: _____
- Increase/Decrease quantity from: _____ to: _____
- Price shows: _____ should be: _____
- Decrease remaining encumbrance and close contract
- Increase encumbrance and close contract
- Decrease encumbrance
- Increase encumbrance

DECISION MEMO REQUIRED

- Increase (greater than 29 days) contract expiration from: _____ to: _____
- Increase ≥ \$2,500.00, or ≥ 10%, of current contract amount Funding Source _____
- OTHER - explain below:

<u>Dse</u>		<u>6/17/26</u>	<u>MC</u>		<u>6/17/26</u>
Prepared By (Initials)	Phone Ext	Date	Recommended for Approval (Initials)	Phone Ext	Date

REVIEWED BY (Initials Only)

		<u>[Signature]</u>	<u>7/1/2026</u>
Buyer	Date	Procurement Officer	Date
Chief Financial Officer (Decision Memos Over \$25,000)	Date	Chairman's Office (Decision Memos Over \$25,000)	Date



File #: FM-P-0021-26

Agenda Date: 7/7/2026

Agenda #: 8.A.

AWARDING RESOLUTION
ISSUED TO JOHNSON CONTROLS BUILDING SOLUTIONS LLC,
FOR THE METASYS SERVER SOFTWARE UPGRADE
FOR FACILITIES MANAGEMENT
(CONTRACT AMOUNT NOT TO EXCEED: \$52,385.00)

WHEREAS, pursuant to Intergovernmental Agreement between the County of DuPage and Sourcewell, the County of DuPage will contract with Johnson Controls Building Solutions LLC; and

WHEREAS, the Public Works Committee recommends County Board approval for the issuance of a contract to Johnson Controls Building Solutions LLC, to upgrade the existing Metasys Server Software, for the period July 14, 2026 through July 13, 2027, for Facilities Management.

NOW, THEREFORE BE IT RESOLVED, that County Contract, covering said, to upgrade the existing Metasys Server Software, for the period July 14, 2026 through July 13, 2027, for Facilities Management, be, and it is hereby approved for issuance of a contract by the Procurement Division to, Johnson Controls Building Solutions LLC, 5757 N Green Bay Ave, Glendale, WI 53209, for a total contract amount not to exceed \$52,385.00.

Enacted and approved this 14th day of July, 2026 at Wheaton, Illinois.

DEBORAH A. CONROY, CHAIR
DU PAGE COUNTY BOARD

Attest: _____
JEAN KACZMAREK, COUNTY CLERK



Procurement Review Comprehensive Checklist
 Procurement Services Division
 This form must accompany all Purchase Order Requisitions

SECTION 1: DESCRIPTION			
<i>General Tracking</i>		<i>Contract Terms</i>	
FILE ID#: 26-1867	RFP, BID, QUOTE OR RENEWAL #:	INITIAL TERM WITH RENEWALS: OTHER	INITIAL TERM TOTAL COST: \$52,385.00
COMMITTEE: PUBLIC WORKS	TARGET COMMITTEE DATE: 07/07/2026	PROMPT FOR RENEWAL:	CONTRACT TOTAL COST WITH ALL RENEWALS: \$52,385.00
	CURRENT TERM TOTAL COST: \$52,385.00	MAX LENGTH WITH ALL RENEWALS: ONE YEAR	CURRENT TERM PERIOD: INITIAL TERM
<i>Vendor Information</i>		<i>Department Information</i>	
VENDOR: Johnson Controls Building Solutions, LLC	VENDOR #:	DEPT: Facilities Management	DEPT CONTACT NAME: Brian Rovik
VENDOR CONTACT: Breanna Dobos	VENDOR CONTACT PHONE: 224-434-8482	DEPT CONTACT PHONE #: x5705	DEPT CONTACT EMAIL: brian.rovik2@dupagecounty.gov
VENDOR CONTACT EMAIL: breanna.lynn.dobos@jci.com	VENDOR WEBSITE:	DEPT REQ #:	
<i>Overview</i>			
DESCRIPTION Identify scope of work, item(s) being purchased, total cost and type of procurement (i.e., lowest bid, RFP, renewal, sole source, etc.). Recommendation for the approval of a contract to Johnson Controls Building Solutions LLC, to upgrade the existing Metasys Server Software, for Facilities Management, for the period July 14, 2026 through July 13, 2027, for a total contract amount not to exceed \$52,385.00. Contract pursuant to the Intergovernmental Cooperation Act – Sourcewell Contract #080824-JHN.			
JUSTIFICATION Summarize why this procurement is necessary and what objectives will be accomplished The existing Metasys server software for the County Campus' Building Automation System (BAS) is out of date and needs to be upgraded. Hardware to support the current BAS has been discontinued and newer hardware is incompatible. The upgraded server will have better performance, faster processors, more expandable memory, and enhanced cybersecurity. Upgrading the server will allow additional future enhancements to be implemented to improve performance and energy reduction strategies.			

SECTION 2: DECISION MEMO REQUIREMENTS	
DECISION MEMO NOT REQUIRED	Select an item from the following dropdown menu to identify why a Decision Memo (Section 3) is not required.
DECISION MEMO REQUIRED	Select an item from the following dropdown menu to identify why a Decision Memo (Section 3) is required.
COOPERATIVE (DPC2-352), GOVERNMENT JOINT PURCHASING ACT (30ILCS525) OR GSA SCHEDULE PRICING	

SECTION 3: DECISION MEMO	
SOURCE SELECTION	Describe method used to select source. Sourcewell posted Request for Proposal #080824, for the procurement HVAC Systems with Related Products and Services, on Thursday, June 20, 2024, and the solicitation remained in an open status within the portal until August 8, 2024, at 4:30 pm CT. Responses were received by thirty (30) vendors and reviewed by the Sourcewell Evaluation Committee. Johnson Controls, Inc. received the most points by the evaluation committee and entered into a contract with Sourcewell on November 26, 2024.
RECOMMENDATION AND TWO ALTERNATIVES	Describe staff recommendation and provide justification. Identify at least 2 other options to accomplish this request, including status quo, (i.e., take no action). 1. Recommendation for the approval of a contract to Johnson Controls Building Solutions LLC, to upgrade the existing Metasys Server Software, for Facilities Management, for the period July 14, 2026 through July 13, 2027, for a total contract amount not to exceed \$52,385.00. Contract pursuant to the Intergovernmental Cooperation Act – Sourcewell Contract #080824-JHN. 2. Take no action and be unable to replace discontinued parts to support the current BAS. 3. Replace entire BAS system at the County Campus.

SECTION 4: SOLE SOURCE MEMO/JUSTIFICATION

JUSTIFICATION	Select an item from the following dropdown menu to justify why this is a sole source procurement.
NECESSITY AND UNIQUE FEATURES	Describe the product or services that are not available from other vendors. Explain necessary and unique features or services. Attach letters from manufacturer, letters from distributor, warranties, licenses, or patents as needed. Be specific.
MARKET TESTING	List and describe the last time the market has been tested on the applicability of the sole source. If it has not been tested over the last 12 months, explain why not.
AVAILABILITY	Describe steps taken to verify that these features are not available elsewhere. Included a detailed list of all products or services by brand/manufacturer examined and include names, phone numbers, and emails of people contacted.

SECTION 5: Purchase Requisition Information

<i>Send Purchase Order To:</i>		<i>Send Invoices To:</i>	
Vendor: Johnson Controls Building Solutions, LLC	Vendor#:	Dept: Facilities Management	Division:
Attn: Breanna Dobos	Email: breanna.lynn.dobos@jci.com	Attn:	Email: FMAccountsPayable@dupagecounty.gov
Address: 3007 Malmo Drive	City: Arlington Heights	Address: 421 N. County Farm Rd.	City: Wheaton
State: IL	Zip: 60005	State: IL	Zip: 60187
Phone: 224-434-8482	Fax:	Phone: 630-407-5700	Fax: 630-407-5701
<i>Send Payments To:</i>		<i>Ship to:</i>	
Vendor: Johnson Controls Building Solutions, LLC	Vendor#:	Dept: Facilities Management	Division:
Attn:	Email:	Attn: Gavin Carroll	Email: Gavin.Carroll@dupagecounty.gov
Address: 5757 N Green Bay Ave	City: Glendale	Address: 410 N. County Farm Rd.	City: Wheaton
State: WI	Zip: 53209	State: IL	Zip: 60187
Phone:	Fax:	Phone: (630) 407-2687	Fax:
Shipping		Contract Dates	
Payment Terms: PER 50 ILCS 505/1	FOB: Destination	Contract Start Date (PO25): Jul 14, 2026	Contract End Date (PO25): Jul 13, 2027

Purchase Requisition Line Details

LN	Qty	UOM	Item Detail (Product #)	Description	FY	Company	AU	Acct Code	Sub-Accts/Activity Code	Unit Price	Extension
1	1	LO		Metasys Server Upgrade	FY26	6000	1220	54107		52,385.00	52,385.00
<i>FY is required, ensure the correct FY is selected.</i>										Requisition Total	\$ 52,385.00

Comments

HEADER COMMENTS	Provide comments for P020 and P025. Metasys Server Software Upgrade. Pursuant to the Intergovernmental Cooperation Act – Sourcewell Contract #080824-JHN.
SPECIAL INSTRUCTIONS	Provide comments for Buyer or Approver (not for P020 and P025). Comments will not appear on PO. Send PO to Vendor, Cathie Figlewski, Gavin Carroll, and Clara Gomez,
INTERNAL NOTES	Provide comments for department internal use (not for P020 and P025). Comments will not appear on PO. PW 7/7/26; CB 7/14/26
APPROVALS	Department Head signature approval for procurements under \$15,000. Procurement Officer Approval for ETSB.

DuPage County Metasys Server Software Upgrade Proposal

1st of July 2026



For the Attention of: Gavin Carroll

Scope Summary

This agreement is in accordance with the Johnson Controls Sourcewell contract #080824-JHN.

We have the pleasure of submitting the proposal for the upgrade of the BAS Server Software and upgrade the existing supervisory controls software to the highest revision possible.



Terms & Conditions

- Proposal is valid for 60 days
- Johnson Controls Standard Terms of Sale apply, included with this quote
- Payment Terms – 60 days from invoice date per the Illinois Prompt Payment Act.

Details on pricing, inclusions and clarifications are included on the following pages. Please do not hesitate to contact me if you require any additional information on the proposal. We look forward to working with you in making this project a success.

Breanna Dobos

Sales Engineer – Building Solutions North America

+1 224 434 8482 Mobile

Breanna.Lynn.Dobos@jci.com

Proposal at a Glance

Description

Metasys Server Software Upgrade Scope of Work

Metasys Server Upgrade Information / Benefits

Metasys Required Hardware / SQL Software Version

Metasys Discounts thru September 2026

Pricing Details on Page 7.

Executive Summary:

Dear Gavin,

The following proposal is for replacing the Metasys Server currently serving the equipment in your facility. The original N2 controllers were developed in the early 1990's and these controllers have served the facility well for many years. Due to a shortage of parts and advancing technology, the N2 controllers have been discontinued. We are currently supporting this product line thru remaining stock and repair parts.

Metasys features an intuitive design, with navigation based in spaces and equipment-serving relationships, helping facility operators identify and correct problems more quickly and making it easier to troubleshoot equipment. These M4 controllers offer additional point capability as well as additional memory and more flexible programming options. This will allow additional future enhancements to be implemented to improve performance and energy reduction strategies.

The increasingly urgent need to protect data and buildings and gain measurable results requires an up-to-date building automation system. Metasys provides a flexible modernization path for customers with the porting over of feature functionality from legacy system components and enhanced replacements for ageing hardware devices.

Metasys is optimized for mobility. Enhancing facility operators' productivity. The Metasys single experience makes a full range of system capabilities available on any device (phones, tablets, laptops, and PCs.). This can assist facility operators to manage their buildings no matter where they are and no matter what device they are using.

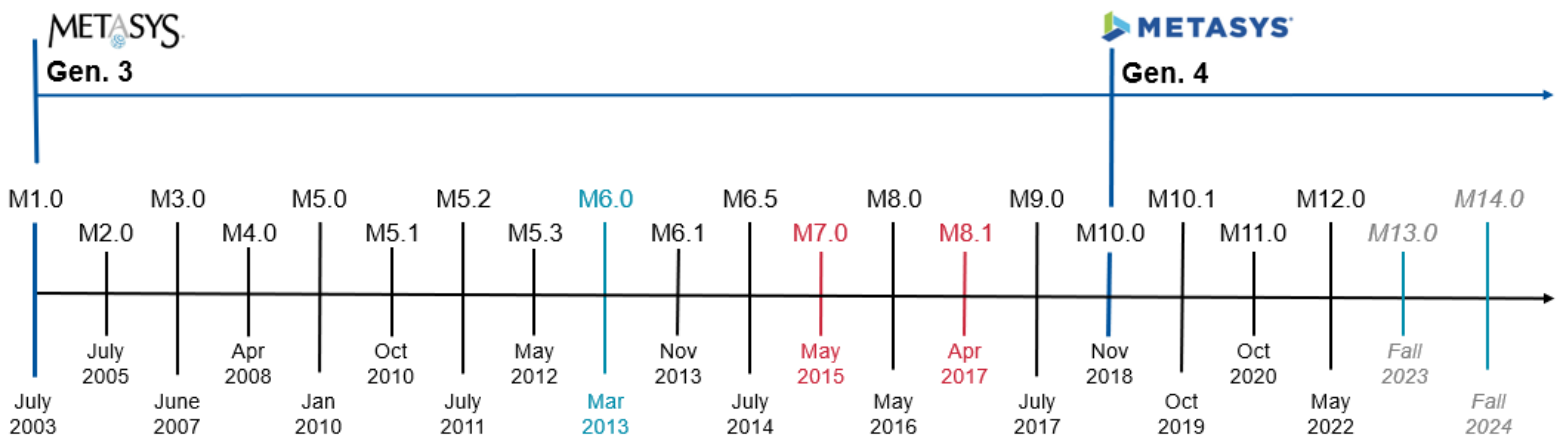

Metasys ADX Server Software Upgrade Scope of Work:

We propose upgrading the existing Metasys server software and supervisory controller software to our latest version possible. After upgrading the server software, the next step would be to upgrade the existing supervisory controllers to our M-4 Series. The new M4-series product line has better performance, faster processors, more expandable memory, and enhanced security.

1. Extended Application & Data Server Software

- The Application and Data Server (ADX) is a component of the Metasys system that manages the collection and presentation of large amounts of trend data, event messages, operator transactions, and system configuration data.
- As Site Director, the ADX provides secure communication to a network of NAE/SNE series engines.

2. Upgrade/Patch Existing Network Engines Software

- Upgrade/Patch the existing NAE supervisory network controller software to the highest Metasys revision possible

3. Existing SMP Graphics

- Backup existing system data.
- Provide SMP License
- Integrate existing graphics to be used on Metasys – This proposal does not include upgrading to MUI Graphics.
- Integrate BACnet compatible devices.

Installation Notes:

- Pricing assumes work/travel is performed during normal 40-hour business week (Monday – Friday). After-hours or overtime service can be provided for additional cost.
- Pricing assumes customer to provide virtual machine environment and any updated SQL software required.
- **NOTE:** This proposal includes JCI material discounts only available through **9/15/26**.
- Does not include any electrical work.
- Includes project management, engineering, and programming/commissioning.
- Does not include any repairs to the existing equipment.
- Does not include upgrading any vendor devices outside of the identified controllers as part of this scope.
- Does not include server hardware or providing SQL software for a physical or virtual machine.
- Pricing subject to change orders based on job specific conditions; change order work will not be executed without proper approvals.

Application and Data Server: Supply, Installation, and Commissioning of (1) ADX Server Software Upgrade

Supply, installation, and commissioning of Application and Data Server (ADX) software upgrade.



Benefits of Application and Data Server (ADX):

1. Long-Term Trend Data Storage
 - Enables the analysis of building systems performance to identify opportunities for efficiency improvements and the development of predictive strategies.
2. Alarm and Event Management
 - Routes event messages to building operators for rapid fault diagnosis and response. Creates an audit trail for later detailed analysis.
3. FIPS 140-2 compliant
 - The ADS/ADX is FIPS 140-2 compliant. FIPS 140-2 uses cybersecurity techniques to prevent unauthorized access to systems and data.
4. Support of IT Standards and Internet Technologies
 - Enables you to install the Application and Data Server on the existing IT infrastructure within the building or enterprise and is compatible with industry-standard firewalls.
5. Secure User Access
 - Authenticates users and authorizes access privileges to protect system integrity.
6. BACnet Secure Connect
 - It is a secure, encrypted datalink layer that is specifically designed to meet the requirements, policies and constraints of IP infrastructures.
7. Flexible System Navigation and Dynamic User Graphics
 - Enable customization of system presentation for different users to enhance information access and facilitate system operation.

Proposed BMS Headend Specifications

Proposed BMS Headend Specs:

This hardware and associated software are required for compatibility with the latest version of Metasys. DuPage County IT Department to provide either hardware or virtual machine with SQL to handle updated Metasys server software.

<p>Recommended Computer Platform ¹</p>	<p>Intel® Xeon® Gold 5222 3.8 GHz, 4 cores/8 threads, 10.4GT/s, 16.5M Cache, Turbo, HT (105W) DDR4-2933 and recommended second processor type is Intel® Xeon® Gold 5222 3.8 GHz, 4 cores/8 threads, 10.4GT/s, 16.5M Cache, Turbo, HT (105W) DDR4-2933</p> <p>Hard drive: 2 x 960 GB SSD SATA Mix Use 6Gbps 512 2.5in Hot-plug Drive (RAID 1) 2 with 40 GB free space after installation of all prerequisite software and before installation of ADS software. Configure RAID 1 (mirroring) with disk write-caching turned on.</p> <p>Note: ADX prerequisite software includes the Windows operating system, SQL Server software, Windows .NET Framework, and any other software or SPs required by your ADX configuration.</p>
<p>Required Minimum Memory ³</p>	<p>32 GB RDIMM, 2933MT/s, Dual Rank</p>
<p>Supported Operating Systems ⁴</p>	<p>Windows® Server® 2022 (64-bit)</p> <p>Windows® Server® 2019 (version 1809 or later) (64-bit)</p> <p>Supports:</p> <ul style="list-style-type: none"> • SQL Server® 2022 with CU9 (64-bit) • SQL Server® 2019 with CU18 (64-bit) <p>Note: SQL Server 2019 or later may cause the configuration service cache that builds stored procedures to time out. This causes the user's logon to Metasys UI to fail. To resolve this issue, set SQL Server 2019 or later databases to run in 2017 compatibility mode. For more information, refer to docs.microsoft.com</p> <ul style="list-style-type: none"> • SQL Server® 2017 with CU31 (64-bit)

Johnson Controls FY26 MUMS Program Discounts

Server:

- 40% off Metasys Upgrade or Migration Software
- 40% off Metasys 1- or 3-year Software Subscriptions
- 40% off Metasys Fault Detection and Fault Triage Software

Supervisory Controllers:

- 30% off Qty. 2-5 M4 Network or Control Engines and Panels
- 40% off Qty. 6-10 M4 Network or Control Engines and Panels
- 50% off Qty. 10+ M4 Network or Control Engines and Panels

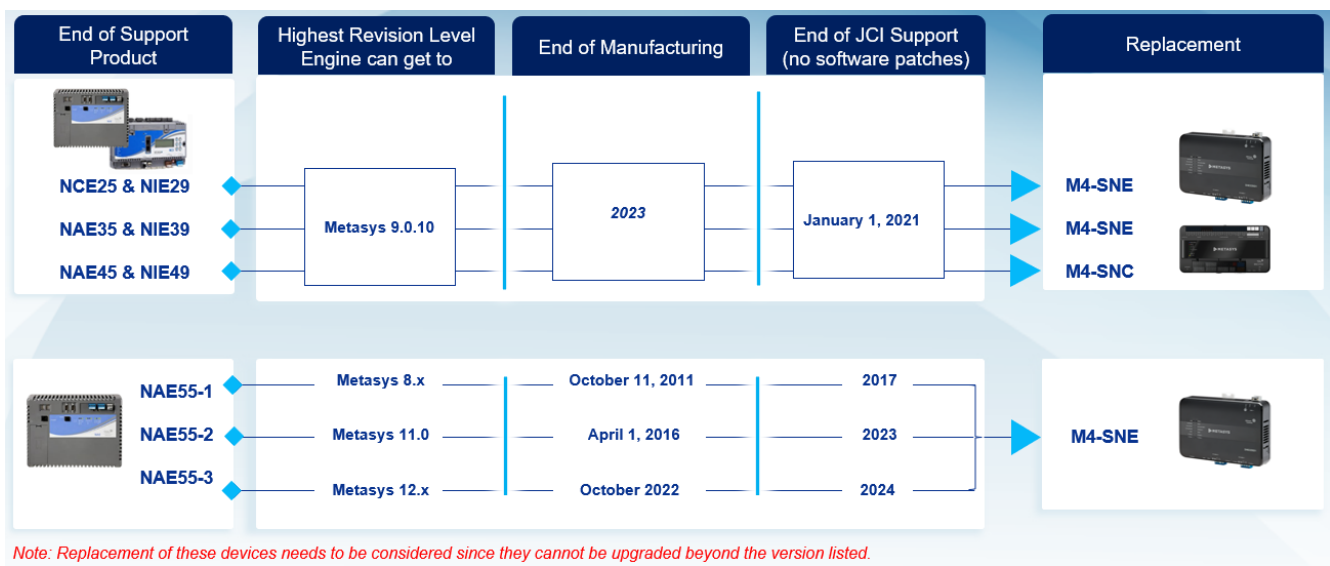

Field Controllers:

- 25% off Qty. 5-20 New M4 Field Controllers
- 35% off Qty. 20+ New M4 Field Controllers
- 20% off NS8000 Sensors

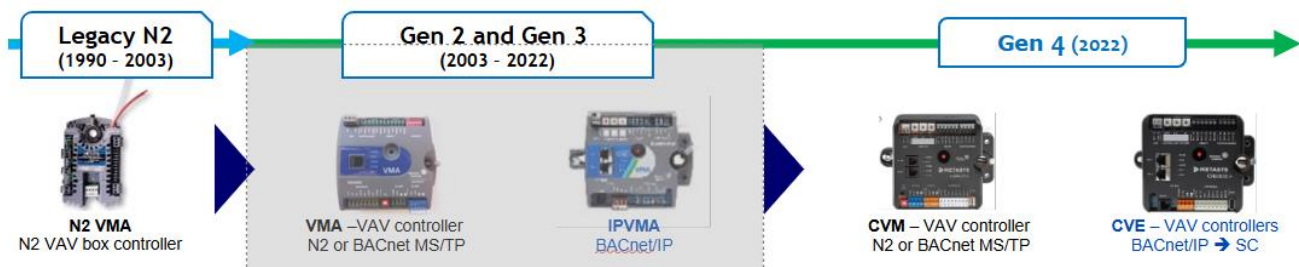

Note: These discounts are subject to change at the start of each new Johnson Controls fiscal year. The current discounts shown above are valid thru September 2026. All material orders must be placed by September 15th, 2026.

Pricing Summary:

Note: Below Pricing is subject to change with product cost increases and labor increases.

Description	Price
Metasys ADX Server Software Upgrade – 25 Concurrent Users (Currently at DuPage County)	\$ 52,385.00

Clarifications/Exclusions:

- **Includes rebate for ADX upgrade which is good thru 09/15/2026.**
- **All work is to be performed during normal working hours unless specified otherwise.**
- **Due to raw material pricing volatility, pricing shown may be subject to upcoming price increases.**
- **Additional discounts may be available if all work is executed under one mobilization project in lieu of multiple phases.**
- The customer must provide a network with internet connection for remote access to be possible.
- All 3rd party equipment required for this project will be subject to supplier lead times for equipment. To be confirmed at time of received purchase order.
- Any works not specifically mentioned / changes in the scope of work will be classified as a variation to the agreement, and as such will incur an additional charge.
- Our proposal is based on the standard JCI Terms and Conditions which are attached at the end of this proposal.
- This proposal does not allow for any fire-related work.
- No allowance has been allowed in this proposal for the replacement/repair of any existing controls or equipment found to be faulty during the work. If repairs are needed, an add price will be given.

CUSTOMER ACCEPTANCE:

This Proposal constitutes an offer and is subject to, and expressly conditional upon Buyer's acceptance of the Standard Equipment Terms and Conditions attached hereto (the "Terms and Conditions"), which are incorporated herein by reference. Buyer accepts this offer by signing and returning this Proposal, by issuing a purchase order to Johnson Controls for the proposed work, by instructing Johnson Controls to commence performance of the proposed work, or by accepting or paying for the goods, materials, service or equipment that are the subject of this Proposal, whichever occurs first. In accepting this Proposal, Buyer unconditionally agrees to the terms and conditions contained herein including those on the following page(s) of this Proposal and any attachments or riders attached hereto that contain additional terms and conditions. It is understood that the Johnson Controls Terms and Conditions shall prevail over any different or additional terms and conditions on any purchase order or other document that Buyer may issue, and Johnson Controls expressly objects to any such different or additional terms. Any changes requested by Buyer after the execution of this Agreement shall be paid for by the Buyer and such changes shall be authorized in writing. **ATTENTION IS DIRECTED TO THE LIMITATION OF LIABILITY, WARRANTY, INDEMNITY AND OTHER CONDITIONS CONTAINED IN THE TERMS AND CONDITIONS.**

Total sell price is contingent upon the following billing and payment terms: Invoices will be delivered via email, payment due date of NET 60, including a deposit invoice for 25% or as mutually agreed to prior to approved submittal and equipment release to the factory. **Johnson Controls will not commence work until receipt of the deposit.** All invoices are to be paid via ACH/EFT bank transfer. Johnson Controls' ACH/EFT bank transfer details will be forth coming upon contractual agreement.

This offer shall be void if not accepted in writing within thirty (30) days from the date first set forth above.

To ensure that Seller is compliant with your company's billing requirements, please provide the following information:

PO is required to facilitate billing: **NO:** This signed contract satisfies requirement

YES: Please reference this PO Number: _____

AR Invoices are accepted via e-mail: **YES:** E-mail address to be used: _____

NO: Please submit invoices via mail **NO:** Please submit via _____

Standard Terms and Conditions – U.S.A. and Canada

“JCI” or “Johnson Controls” shall mean Johnson Controls, Inc. for work performed in the U.S.A. and Johnson Controls Canada LP for work performed in Canada. These terms and conditions are an integral part of JCI’s offer and form the basis of any agreement (the “Agreement” resulting from JCI’s proposal for the goods and/or services described. By accepting this proposal, Purchaser agrees to be bound by the following terms and conditions:

(1) AGREEMENT AND LIMITATIONS. These Standard Equipment Terms and Conditions apply to all quotations and proposals (each, a “Quotation”) made by Johnson Controls Building Solutions, LLC (“Seller”) and to the sale of all products or equipment (“Equipment”) or the performance of services (“Services”) by Seller to any purchaser thereof (“Buyer”), unless Seller subsequently and expressly agrees to their modification in writing signed by an authorized representative of Seller. These Standard Terms and Conditions are incorporated into Seller’s Quotation and any related purchase order or acknowledgement. The Quotation is expressly limited to, and expressly conditional on, Buyer’s acceptance of these Standard Terms and Conditions. Buyer unconditionally accepts the Quotation and these Standard Terms and Conditions by signing and returning Seller’s Quotation, by sending a purchase order in response to the Quotation, by instructing to Seller to begin work, including shipment of Equipment or performance of services, or by accepting or paying for the Equipment or Service, whichever occurs first. Upon Buyer’s acceptance, Seller’s Quotation and the related terms and conditions referred to in the Quotation shall constitute the entire agreement relating to the Equipment and services covered by the Quotation (the “Agreement”). No terms, conditions or warranties other than those identified in the Quotation and no agreement or understanding, oral or written, in any way purporting to modify such terms and conditions whether contained in Buyer’s purchase order or shipping release forms, or elsewhere, shall be binding on Seller unless hereafter made in writing and signed by Seller’s authorized representative. Buyer is hereby notified of Seller’s express rejection of any terms inconsistent with these Standard Terms and Conditions. Neither Seller’s subsequent lack of objection to any such terms, nor the delivery of the Equipment or services, shall constitute an agreement by Seller to any such terms. These Standard Terms and Conditions may be modified or rescinded only by a writing signed by authorized representatives of both Seller and Buyer.

(2) TERMINATION; CANCELLATION. If either party materially breaches this agreement, the other party may notify the breaching party in writing, setting out the breach, and the breaching party will have 60 days following such notice to remedy the breach. If the breaching party fails to remedy the breach during that period, the other party may by written notice terminate the Agreement. Accepted orders may be cancelled or modified by Buyer only with Seller’s express written consent. If cancellation or modification is allowed, Buyer agrees to pay to Seller all expenses incurred and damage sustained by Seller on account of such cancellation or modification. At a minimum, Buyer agrees to pay the following cancellation charges if Seller consents to cancellation in writing: For custom units, prior to release to fabrication, a booking charge of five percent (5%) of total sale price for such units will be assessed. For custom units after release for fabrication, cancellation charges shall be calculated according to the following formula: Cancellation charge = $(X + 0.1) \times \text{custom equipment sell price} / Y$, where X = number of weeks from date of release for fabrication to the date of Buyer notice of cancellation and Y = number of weeks for delivery as offered at the time of the contract. Cancellation charges shall not exceed fifty percent (50%) of the total Equipment sell price. If Seller’s performance of its obligations is prohibited because of changes in applicable laws, regulations, or codes, or becomes impracticable due to obsolescence or unavailability of systems, equipment, or products (including component parts and/or materials) or because the Seller or its supplier(s) has discontinued the manufacture or the sale of the equipment and/or products or is no longer in the business of providing the Services, Seller may terminate this Agreement, or the affected portions, at its sole discretion upon notice to Buyer. Seller may terminate this Agreement, or the affected portions, at its sole discretion upon notice to the Buyer. Seller reserves the right to cancel any

sale hereunder prior to delivery in Seller’s sole discretion without liability to Buyer (except for refund of monies already paid).

(3) PRICE, DEPOSIT, SHIPMENT, PAYMENT AND INVOICING. All purchases and related payments will be in US Dollars unless otherwise stated on the applicable Equipment or Service Quotation. Seller may increase prices upon notice to the Buyer to reflect increases in material and labor costs. Prices may be adjusted by Seller prior to shipment to take into account increases in the cost of raw materials, component parts, third party products or labor rates or applicable Taxes, Trade Restrictions (as defined below); government actions; or to cover any unforeseen or other extra cost elements. “Trade Restrictions” means any additional or new tariff/duty, quota, tariff-rate quota, or cost associated with the withdrawal of tariff/duty concessions pursuant to a trade agreement(s). Unless otherwise agreed in writing by Seller and Buyer, Seller will deliver the Equipment, DAP (Incoterms® 2020) customer’s specified delivery address (the “Delivery Location”), using Seller’s standard methods for packaging and shipping same. Buyer is responsible for obtaining any import licenses and other consents. Buyer agrees to pay a percentage deposit of the sell price (pre-tax) as set forth in Seller’s Quotation upon approved submittal and prior to Seller release to factory. Seller will generate an invoice for the required deposit amount after Seller’s receipt of a written agreement or order from Buyer, in advance of release to factory. Seller will not start manufacture until receipt of the deposit. Unless otherwise specified in the Quotation, Seller shall invoice Buyer for progress payments to 100% percent based upon Equipment delivered or stored, and Services performed. Unless otherwise agreed to in writing by Seller, all payments are due within sixty (60) days from the date of invoice, in accordance with the provisions of the Illinois Local Government Prompt Payment Act, 50 ILCS 505/1 *et seq.* Invoices shall be paid by Buyer via electronic delivery via EFT/ACH. If Seller consents to payment by credit card in lieu of EFT/ACH, Seller may charge additional fees. Seller may, at its sole option, have the right to make any delivery under this Agreement payable on a cash or payment guarantee before shipment basis. In the case of export sales, unless otherwise agreed to in writing by Seller, all payments are to be made by means of a confirmed irrevocable letter of credit. Buyer must notify Seller in writing of any invoicing disputes within 21 days of the date of invoice or else such disputes are waived. Buyer and Seller shall seek to resolve any such disputes expeditiously and in good faith within 21 days of the dispute notice. Payments of any disputed amounts are due and payable upon resolution. All undisputed amounts remain due within sixty (60) days from the date of invoice. This Agreement is entered into with the understanding that the services to be provided by Seller are not subject to any local, state, or federal prevailing wage statute. If it is later determined that local, state, or federal prevailing wage rates apply to the services to be provided by Seller, Seller shall be entitled to a modification or change order to adjust the Quotation price to reflect the required prevailing wage rate. Buyer agrees to pay for the applicable prevailing wage rates. Buyer shall provide financial information requested by Seller to verify Buyer’s ability to pay for goods or services. If Seller, in its sole discretion determines that reasonable grounds exist to question Buyer’s ability or willingness to make payments when due (e.g., not making payments when due, late payments, or a reduction in Buyer’s credit score), Seller may defer shipments, change payment terms, require cash in advance and/or require other security, without liability and without waiving any other remedies Seller may have against Buyer. Seller shall provide Buyer with advance written notice of changes to payment terms. In the event of Buyer’s default, the balance of any outstanding amounts will be immediately due and payable. Buyer acknowledges and agrees that timely payments of the full amounts listed on invoices is an essential term of this Agreement and that Buyer’s failure to make payment in full when due is a material breach of this Agreement. Buyer further acknowledges that if Buyer fails to timely pay any undisputed amount invoices, such failure is a material breach and will give Seller, without prejudice to any other right or remedy, the right to, without notice: (i) if the failure continues for five (5) days following Buyer’s receipt of notice thereof, suspend, discontinue or terminate performing

any services and/or withhold further deliveries of Equipment, terminate or suspend any unpaid software licenses, and/or suspend Seller's obligations under or terminate this Agreement; and (ii) charge Buyer interest on the amounts unpaid at a rate equal to one and one half (1.5) percent per month or, if lower, the maximum rate permitted under applicable law, from the applicable due date until payment is made in full. Seller's election to continue performing does not in any way diminish Seller's right to terminate or suspend services or exercise any or all rights or remedies under this Agreement. Seller shall not be liable for any damages, claims, expenses, or liabilities arising from or relating to suspension or termination of performance for Buyer's non-payment. If there are exigent circumstances requiring services or Seller otherwise performs services at the premises following suspension, those services shall be governed by the terms of this Agreement unless a separate contract is executed. If Buyer disputes any late payment notice or Seller's efforts to collect payment. Buyer shall immediately notify Seller in writing and explain the basis of the dispute.

(4) TAXES/TARIFFS. Prices do not include applicable taxes, fees, duties, tariffs, false alarm assessments, permits and levies or other charges imposed and/or enacted by a government, however designated or imposed (collectively, "Taxes"). All Taxes are the responsibility of Buyer, unless Buyer presents an exemption certificate acceptable to Seller and the applicable taxing authorities. If Seller is required to pay any such Taxes or other charges, Buyer shall reimburse Seller on demand. If any such exemption certificate is invalid, then Buyer will immediately pay Seller the amount of the Taxes, plus penalties and interest.

(5) DELIVERY. The delivery date(s) provided by Seller for the Equipment is only an estimate and is contingent on prompt receipt of all necessary information from Buyer. The delivery date(s) is subject to and shall be extended by delays caused by acts a Force Majeure Event (as defined herein in Section 13(h)). FAILURE TO DELIVER WITHIN FIVE (5) DAYS OF THE ESTIMATED DELIVERY DATE SHALL NOT BE A MATERIAL BREACH OF CONTRACT ON SELLER'S PART. If Buyer causes Seller to delay shipment or completion of the Equipment, Seller shall be entitled to any and all extra cost and expenses resulting from such delay. At time of delivery, Buyer shall provide and be responsible for all rigging costs to remove or place the equipment, and Buyer shall ensure the delivery site has an appropriate rigging yard or laydown area. Seller may, in its sole discretion, without liability or penalty, make partial shipments of Equipment to Buyer. Each shipment will constitute a separate sale, and Buyer will pay for the units shipped whether the shipment is in whole or partial fulfillment of Buyer's purchase order. Risk of loss or damage passes to Buyer upon Delivery. If Buyer fails to accept delivery of any of the Equipment on the date set forth in Seller's notice that Seller has delivered the Equipment to the Delivery Location, or if Seller is unable to deliver the Equipment to the Delivery Location on the date because Buyer has failed to provide appropriate instructions, documents, licenses, or authorizations, then: (i) the Equipment will be deemed to have been delivered to Buyer; and (ii) Seller, at its option, (A) may store the Equipment until Buyer takes possession of them, at which time Buyer will be liable for all costs and expenses resulting therefrom (including but not limited to the cost of storage and insurance during the storage period), or (B) ship the Equipment to Buyer, at Buyer's cost and expense. Title to Equipment and hardware manufactured by a third party ("Third Party Hardware") passes to Buyer upon delivery of Equipment and/or Third-Party Hardware to the Delivery Location. Unless Buyer has prepaid for the Equipment or Third-Party Hardware, the Equipment and Third-Party Hardware in Buyer's inventory shall be subject to a security interest of Seller in the Equipment and Third-Party Hardware until Seller receives full payment from Buyer. Seller may, in its reasonable discretion, register such security interest in Equipment and Third-Party Hardware and their sale proceeds pending payment in the applicable official registers of any national or local jurisdiction where Equipment and/or Third-Party Hardware are delivered or physically located. Promptly upon Seller's request, Buyer shall execute all documents and take all actions as Seller reasonably directs at Seller's expense to enable Seller to exercise its security rights under this Section. Title to any software licensed to Buyer under these Terms will remain with Seller and its suppliers and licensors and is provided under the terms of the applicable EULA.

(6) INSPECTION. As used in this Section, "Nonconforming Equipment" means only the following: (i) the items shipped are different from those identified in Buyer's purchase order; or (ii) the labels or packaging of the items incorrectly identifies them. Buyer will inspect the Equipment within five (5) days following receipt thereof (the "Inspection Period"). The Equipment will be deemed accepted at the end of the Inspection Period unless Buyer notifies Seller in writing of any Nonconforming Equipment and furnishes Seller with written evidence or other documentation reasonably required by Seller. If Buyer notifies Seller of any Nonconforming Equipment prior to expiration of the Inspection Period, then Seller will, in its sole discretion, (i) replace the Nonconforming Equipment with conforming Equipment, or (ii) credit or refund the purchase

price for the Nonconforming Equipment, together with any reasonable shipping and handling expenses incurred by Buyer. At Seller's request and direction, Buyer will return the Nonconforming Equipment at Seller's expense or dispose of the Nonconforming Equipment in a manner approved by Seller, and upon request Buyer shall provide Seller with a certificate of destruction of such Nonconforming Equipment. Upon receipt of the Nonconforming Equipment, Seller will promptly refund the monies owed or ship the replacement Equipment to the Delivery Location at Seller's expense, with Seller retaining the risk of loss until delivery. Buyer acknowledges and agrees that the remedies set forth in this Section are Buyer's exclusive remedies and Seller's sole liability for the delivery of Nonconforming Equipment, and except as set forth in this Section, Buyer has no right to return the Products to Seller without Seller's written authorization.

(7) LIMITED WARRANTY. Seller warrants that the Equipment furnished by Seller under the Agreement will be free from defects in material and workmanship for a period of twelve (12) months from initial product startup, or eighteen (18) months from product shipment, whichever occurs first (the "Warranty Period") unless such Warranty Period is modified by Seller's Quotation or the supplied separate written product warranty accompanying the Equipment. No warranty is provided for third-party products and equipment installed or furnished by Seller. Such third-party products and equipment are provided with the third-party manufacturer's warranty to the extent available, and Seller will transfer the benefits together with all limitations of that manufacturer's warranty to Buyer. This limited warranty does not cover failures or defects caused in whole or in part by (i) misuse, neglect, accident or improper installation or maintenance performed by anyone other than Seller; (ii) Force Majeure, improper storage or protection of equipment from date of shipment until start-up, or other causes beyond the control of Seller; (iii) normal wear and tear or corrosion; (iv) improper use, application or operation beyond rated capacity; (v) use of replacement parts, refrigerants, oil, additives, or antifreeze agents other than those authorized by Seller; or (vi) any Equipment manufactured or customized according to Buyer's specifications and not authorized in writing by Seller. To qualify for warranty consideration, Buyer must notify Seller in writing of its warranty claim prior to expiration of the Warranty Period to obtain instructions on warranty procedures and provide Seller with reasonable site access to inspect the Equipment and/or perform any necessary warranty work within 72 hours of any access request by Seller. Seller's sole obligation for breach of this warranty, at Seller's option, shall be to repair or to replace defective parts or to properly redo defective Services, to provide equivalent replacement equipment instead of repair parts, or to offer a replacement price allowance to be applied toward the purchase of new or refurbished equipment offered by Seller. This limited warranty does not cover costs of consumable parts and components (e.g., oil, coolant, refrigerant, batteries, gaskets, O-rings, sacrificial anodes, filters, belts and kits), or additional costs for access and transportation. Further details on covered costs, claims processing and actions that may void this warranty are set forth in the applicable Certificate of Limited Warranty. This limited warranty is expressly conditioned on Buyer's proof of payment of the purchase price in full, and all replaced Equipment becomes Seller's property. Any changes/extension to the Warranty Period that may be required due to project delays or slippage will be mutually agreed upon in writing by the parties and may require contract modifications to incorporate additional warranty products to accommodate such change/extension. THIS WARRANTY IS EXCLUSIVE AND IS PROVIDED IN LIEU OF ALL OTHER EXPRESS OR IMPLIED WARRANTIES INCLUDING, WITHOUT LIMITATION, ANY WARRANTY OF MERCHANTABILITY OR FITNESS FOR A PARTICULAR PURPOSE, WHICH ARE HEREBY DISCLAIMED. Seller makes no and specifically disclaims all representations or warranties that the Services, Equipment, Software or third-party product or software will be secure from cyber threats, hacking or other similar malicious activity or will detect the presence of, or eliminate, treat, or mitigate the spread, transmission, or outbreak of any pathogen, disease, virus or other contagion, including but not limited to COVID 19. Unless agreed to in writing by the parties, any technical support, assistance, or advice ("Technical Support") provided by Seller, such as suggestions as to design use and suitability of the Equipment for Buyer's application, is provided in good faith, but Buyer acknowledges and agrees that Seller is not the designer, engineer, or installer of record and is not providing any professional design services hereunder. Any Technical Support is provided for informational purposes only and shall not be construed as professional design services or as a representation or warranty, express or implied, concerning the proper selection, use, and/or application of Equipment. Buyer assumes exclusive responsibility for determining if the Equipment supplied by Seller is suitable for its intended application and all risk and liability, whether based in contract, tort or otherwise, in connection with its application and use of the Equipment.

(8) INTELLECTUAL PROPERTY. Buyer acknowledges Seller and its affiliates are the owners or licensors of brands, trademarks, designs, patents, copyrights and other intellectual property relating to Seller's Equipment, and that no right or license is conveyed to Buyer or any manufacturer, distributor, reseller, or

modify, import, copy such Equipment. Buyer agrees that it will reference brands of Seller or its affiliates only in connection with the use or sale of Equipment delivered to Buyer hereunder, and not in connection with the sale of any other Equipment, except as separately authorized by Seller in writing. Buyer further agrees that it will not, directly or through intermediaries, reverse engineer, decompile, or disassemble any software (including firmware) comprising or contained within Equipment, except and only to the extent that such activity may be expressly permitted, notwithstanding this limitation, either by applicable law or, in the case of open-source software, the applicable open-source license.

(9) REMEDIES AND LIMITATIONS OF LIABILITY. Except as set forth in Paragraph 8 below regarding patents, Buyer agrees that Seller shall be responsible only for such injury, loss, or damage caused by the intentional misconduct or the negligent act or omission of Seller. If Buyer claims Seller has breached any of its obligations, whether of warranty or otherwise, Seller may request the return of the Equipment and tender to Buyer the purchase price paid by Buyer, and in such event, Seller shall have no further obligation under the Agreement except to refund such purchase price upon redelivery of the Equipment. If Seller so requests the return of the Equipment, the Equipment shall be redelivered to Seller in accordance with Seller's instructions and at Seller's expense. The remedies contained in these Standard Terms and Conditions shall constitute the sole recourse of Buyer against Seller for breach of any of Seller's obligations under the Agreement, whether of warranty or otherwise. To the maximum extent permitted by law, in no event shall Seller and its affiliates and their respective personnel, suppliers and vendors ("Seller Parties") be liable to Buyer or any third party under any cause of action or theory of liability, even if advised of the possibility of such damages, for any: (a) special, indirect, incidental, punitive, or consequential damages; (b) lost profits, revenues, data, Buyer opportunities, business, anticipated savings or goodwill; (c) business interruption; or (d) data loss or other losses arising from viruses, ransomware, cyber-attacks or failures or interruptions to network systems. In any case, and to the fullest extent permitted by law, the entire aggregate liability of the Seller Parties under this Agreement for all damages, losses and causes of action, whether in contract, tort (including negligence), or otherwise shall be limited to the purchase price paid by Buyer hereunder for the Equipment giving rise to the claim or \$10 million U.S. Dollars whichever is less.

(10) PATENT INDEMNITY. Seller shall defend or, at its own option settle, any action against Buyer brought by a third party to the extent that the action is based upon a claim that the equipment provided under the Agreement infringes any U.S. patents or copyrights for Buyers located in the United States or Canadian patents or copyrights, for Buyers located in Canada, or misappropriates any trade secrets of a third party (any of the foregoing, a "Claim"), provided that: (i) Buyer gives Seller full authority to defend or settle any such Claim, and (ii) Buyer gives Seller proper and full information and assistance, at Seller's expense (except for Buyer's employees' time) to defend or settle any such Claim. Seller will pay those costs and damages finally awarded against Buyer in the action that are specifically attributable to the Claim, or those costs and damages agreed to in a monetary settlement of the action. Nothing contained herein shall be construed as prohibiting the Buyer, its officers, agents, or its employees, from defending through the selection and use of their own agents, attorneys and experts, any claims, actions or suits brought against them. Seller shall likewise be liable for the cost, fees and expenses incurred in the defense of any such claims, actions, or suits. Nothing contained herein shall be construed as constituting a waiver of Buyer's defenses or immunities under the Local Government and Governmental Employees Tort Immunity Act, 745 ILCS 10/1 et seq. by reason of indemnification or insurance. THE FOREGOING IS IN LIEU OF ANY WARRANTIES OF NONINFRINGEMENT, WHICH ARE HEREBY DISCLAIMED. The foregoing obligation of Seller does not apply with respect to Equipment or portions or components thereof (a) not supplied by Seller, (b) made in whole or in part in accordance with specifications furnished by Buyer, (c) which are modified after shipment by Seller, if the alleged infringement related to such modification, (d) combined with other products, processes or materials where the alleged infringement relates to such combination, (e) where Buyer continues allegedly infringing activity after being notified thereof and/or after being informed of modifications that would have avoided the alleged infringement without significant loss of performance or functionality, or (f) where the Claim is incident to an infringement not resulting primarily from the Equipment. Buyer will indemnify Seller and its officers, directors, agents, and employees from all damages, settlements, attorneys' fees and expenses related to a claim of infringement, misappropriation, defamation, or violation of rights of publicity or privacy excluded from Seller's indemnity obligation herein.

(11) DISPUTES. Seller shall have the sole and exclusive right to determine

whether any dispute, controversy or claim arising out of or relating to the Agreement, or the breach thereof, shall be submitted to a court of law or arbitrated. For Buyers located in the United States, the laws of Illinois shall govern the validity, enforceability, and interpretation of this Agreement, without regard to conflicts of law principles thereof, and the exclusive venue for any such litigation or arbitration shall be in DuPage County, Illinois. For Buyers located in Canada, this Agreement shall be governed by and be construed in accordance with the laws of Ontario, without regard to conflicts of law principles thereof, and the exclusive venue for any such litigation or arbitration shall be in Ontario, Canada. The parties waive any objection to the exclusive jurisdiction of the specified forums, including any objection based on forum non conveniens. If the matter is submitted to arbitration by Seller, the costs of arbitration shall be borne equally by the parties, and the arbitrator's award may be confirmed and reduced to judgement in any court of competent jurisdiction. Except as provided below, no claim or cause of action, whether known or unknown, shall be brought by either party against the other more than one year after the claim first arose. Claims not subject to the one-year limitation include claims for unpaid amounts due under this Agreement.

(12) DIGITAL ENABLED SERVICES; DATA. If Seller provides Digital Enabled Services under this Agreement, these Digital Enabled Services require the collection, transfer and ingestion of building, equipment, system time series, and other data to Seller's cloud-hosted software applications. Buyer consents to and grants Seller the right to collect, transfer, ingest and use such data to enable Seller and its affiliates and agents to provide, maintain, protect, develop and improve the Digital Enabled Services and Seller products and services. Buyer acknowledges that, while Digital Enabled

Services generally improve equipment performance and services, Digital Enabled Services do not prevent all potential malfunction, insure against all loss, or guarantee a certain level of performance. Buyer shall be solely responsible for the establishment, operation, maintenance, access, security and other aspects of its computer network ("Network"), shall appropriately protect hardware and products connected to the Network and will supply Seller secure Network access for providing its Digital Enabled Services. As used herein, "Digital Enabled Services" mean services provided hereunder that employ Seller software and related equipment installed at Buyer facilities and Seller cloud-hosted software offerings and tools to improve, develop, and enable such services. Digital Enabled Service may include, but are not limited to, (a) remote servicing and inspection, (b) advanced equipment fault detection and diagnostics, and (c) data dashboarding and health reporting. If Buyer accesses and uses Software that is used to provide the Digital Enabled Services, the Software Terms (defined below) will govern such access and use. Certain equipment sold hereunder includes by default Seller's Connected Equipment Services. Connected Equipment Services is a data-analytics and monitoring Software platform that uses a cellular or network connection to gather equipment performance data to assist Seller in advising Buyer on (and Buyer in better understanding) such equipment's health, performance or potential malfunction. If Buyer's equipment includes Connected Equipment Services, such services will be on by default and the remote connection will continue to connect to Buyer's Equipment through the full equipment lifecycle, unless Buyer specifically requests in writing that Seller disable the remote connection, or Seller discontinues or removes such remote connection.

(13) SELLER DIGITAL SOLUTIONS. Use, implementation, and deployment of the software and hosted software products ("Software") if any, furnished by Seller shall be subject to, and governed by, Seller's standard terms for such Software and Software related professional services in effect from time to time at www.johnsoncontrols.com/techterms (collectively, the "Software Terms"). Specifically, the Seller General EULA set forth at www.johnsoncontrols.com/buildings/legal/digital/generaleula governs access to and use of software installed on Buyer's premises or systems and the Seller Terms of Service set forth at www.johnsoncontrols.com/buildings/legal/digital/generaltos govern access to and use of hosted software products. The applicable Software Terms are incorporated herein by this reference. Other than the right to use the Software as set forth in the Software Terms, Seller and its licensors reserve all right, title, and interest (including all intellectual property rights) in and to the Software and improvements to the Software. The Software that is licensed hereunder is licensed subject to the Software Terms and not sold. If there is a conflict between the other terms herein and the Software Terms, the Software Terms shall take precedence and govern with respect to rights and responsibilities relating to the Software, its implementation and deployment and any improvements thereto.

Notwithstanding any other provisions of this Agreement, unless otherwise agreed, the following terms apply to Software that is provided to Buyer on a subscription basis (i.e., a time limited license or use right), (each a "Software Subscription"): Each Software Subscription provided hereunder will commence on the date the initial credentials for the Software are made available (the "Subscription Start Date") and will continue in effect until the expiration of the subscription term noted in the applicable statement of work, order or other applicable ordering document. At the expiration of the Software Subscription, such Software Subscription will renew for consecutive one (1) year terms (each a "Renewal Subscription Term"), upon written agreement of the Parties. To the extent permitted by applicable law, Software Subscriptions purchases are non-cancelable, and the sums paid nonrefundable. Fees for Software Subscriptions shall be paid annually in advance, invoiced on the Subscription Start Date and each subsequent anniversary thereof. Buyer shall pay all invoiced amounts within sixty calendar days after the date of invoice. Payments not made within such time period shall be subject to late charges as set forth in the Software Terms. Unless otherwise agreed by the parties in writing, the subscription fee for each Renewal Subscription Term will be priced at Seller's then-applicable list price for that Software offering. Any use

of Software that exceeds the scope, metrics or volume set forth in this Agreement and applicable SOW will be subject to additional fees based on the date such excess use began.

(14) PRIVACY. Seller as Processor. Where Seller factually acts as Processor of Personal Data on behalf of Buyer (as such terms are defined in the DPA) the terms at www.johnsoncontrols.com/dpa ("DPA") shall apply. Seller as Controller: Seller will collect, process and transfer certain personal data of Buyer and its personnel related to the business relationship between it and Buyer (for example names, email addresses, telephone numbers) as controller and in accordance with Seller's Privacy Notice at <https://www.johnsoncontrols.com/privacy>. Buyer acknowledges Seller's Privacy Notice and strictly to the extent consent is required under applicable law, Buyer consents to such collection, processing and transfer. To the extent consent to such collection, processing and transfer by Seller is required from Buyer's personnel under applicable law, Buyer warrants and represents that it has obtained such consent.

(15) MISCELLANEOUS.

(a) CHANGES OF CONSTRUCTION AND DESIGN: Seller reserves the right to change or revise the construction and design of the Equipment purchased by Buyer, without liability or obligation to incorporate such changes to Equipment ordered by Buyer unless specifically agreed upon in writing reasonably in advance of the delivery date for such Equipment. Buyer agrees to bear the expense of meeting any changes or modifications in local code requirements that become effective after Seller has commenced production of the Equipment.

(b) CHARACTER OF EQUIPMENT AND SECURITY INTEREST: The Equipment delivered by Seller under the Agreement shall remain personal property and retain its character as such no matter in what manner affixed or attached to any structure or property. Buyer grants Seller a security interest in said Equipment, any replacement parts and any proceeds thereof until all sums due Seller have been paid to it in cash. This security interest shall secure all indebtedness or obligations of whatsoever nature now or hereafter owing Buyer to Seller.

(c) INSURANCE: Buyer agrees to insure the Equipment in an amount at least equal to the purchase price against loss or damage from fire, wind, water or other causes. The insurance policies are to be made payable to Seller and Buyer in accordance with their respective interests, and when issued are to be delivered to Seller and held by it. Failure to take out and maintain such insurance shall entitle Seller to declare the entire purchase price to be immediately due and payable and shall also entitle Seller to recover possession of said Equipment.

(d) INSTALLATION: If installation by Seller is included within Seller's Quotation, Buyer shall always provide all of the following at its own expense and pertinent to the installation: i) free, dry, and reasonable access to Buyer's premises; and ii) proper foundations, lighting, power, water and storage facilities reasonably required.

(e) COMPLIANCE WITH LAWS: Seller's obligations are subject to the export administration and control laws and regulations of Canada or the United States with respect to where Seller is performing work or providing goods. Buyer shall comply fully with such laws and regulation in the export, resale or disposition of purchased Equipment. Quotations or proposals made, and any orders accepted by Seller from a Buyer outside of Canada or the United States are with the understanding that the ultimate destination of the Equipment is the country indicated therein. Diversion of the products or equipment to any other destination contrary to Canada or the United States as set out in the Quotation or proposal, is prohibited. Accordingly, if the foregoing understanding is incorrect, or if Buyer intends to divert the Equipment to any other destination, Buyer shall immediately inform Seller of the correct ultimate destination.

(f) BUYER RESPONSIBILITIES: Buyer is solely responsible for the

establishment, operation, maintenance, access, security and other aspects of its computer network ("Network") and shall supply Seller secure Network access for providing its services. Equipment networked, connected to the internet, or otherwise connected to computers or other devices must be appropriately protected by Buyer and/or end user against unauthorized access. Buyer is responsible to take appropriate measures, including performing back-ups, to protect information, including without limit data, software, or files (collectively "Data") prior to receiving the service or Equipment.

(g) LIEN LEGISLATION: Notwithstanding anything to the contrary contained herein, the terms of this Agreement shall be subject to the lien legislation applicable to the location where the Equipment will be installed or Services will be performed, and, in the event of conflict, the applicable lien legislation shall prevail.

(h) FORCE MAJEURE: Neither Party shall be liable, nor in breach or default of its obligations under this Agreement, for any delays, interruption, failure to perform under this Agreement, where such delay, interruption or failure is caused, in whole or in part, directly or indirectly, by a Force Majeure Event. A "Force Majeure Event" is a condition or event that is beyond the reasonable control of the Party, whether foreseeable or unforeseeable, including but not limited to the following: acts of God or natural disasters, acts or omissions of any governmental authority (including, without limitation, change of any applicable law or regulation), disease or public health risks and/or responses thereto, strikes, labor disputes, an increase of 5% or more as a result of Trade Restrictions or other excise taxes for materials to be used on the project, fires, explosions or other casualties, thefts, vandalism, civil disturbances, riots, war or other armed conflict (or the serious threat of same), acts of terrorism, electrical power outages, interruptions or degradations in telecommunications, computer, network, or electronic communications systems, cyber-attacks, or unavailability or shortage of parts, materials, supplies, or transportation. If a Party's performance is delayed, impacted, or prevented by a Force Majeure Event or its continued effects, that Party shall be excused from performance or, at the Party's option, entitled to complete performance and extend any relevant completion date or scheduled milestone by the amount of time that the Party was delayed as a result of the Force Majeure Event, plus such additional time as may be reasonably necessary to overcome the effect of the delay.

(i) ASSIGNMENT: This Agreement is not assignable either Party except with prior written consent of Seller. Seller shall have the right to subcontract any of its obligations under this Agreement without notice to Buyer.

(j) FAR: In the United States, Seller supplies "commercial items" within the meaning of the Federal Acquisition Regulations (FAR), 48 CFR Parts 1-53. As to any Buyer order for a U.S. Government contract, Seller will comply only with those mandatory flow-downs for commercial item and commercial services subcontracts listed either at FAR 52.244-6, or 52.212-5(e)(1), as applicable.

T&C Version: 10/01/2025



MASTER AGREEMENT #080824
CATEGORY: HVAC Systems with Related Products and Services
SUPPLIER: Johnson Controls Inc.

This Master Agreement (Agreement) is between Sourcewell, a Minnesota service cooperative located at 202 12th Street Northeast, P.O. Box 219, Staples, MN 56479 (Sourcewell) and Johnson Controls Inc., 5757 North Green Bay Avenue, Milwaukee, WI 53209 (Supplier).

Sourcewell is a local government and service cooperative created under the laws of the State of Minnesota (Minnesota Statutes Section 123A.21) offering a Cooperative Purchasing Program to eligible participating government entities.

Under this Master Agreement entered with Sourcewell, Supplier will provide Included Solutions to Participating Entities through Sourcewell's Cooperative Purchasing Program.

Article 1:
General Terms

The General Terms in this Article 1 control the operation of this Master Agreement between Sourcewell and Supplier and apply to all transactions entered by Supplier and Participating Entities. Subsequent Articles to this Master Agreement control the rights and obligations directly between Sourcewell and Supplier (Article 2), and between Supplier and Participating Entity (Article 3), respectively. These Article 1 General Terms control over any conflicting terms. Where this Master Agreement is silent on any subject, Participating Entity and Supplier retain the ability to negotiate mutually acceptable terms.

- 1) **Purpose.** Pursuant to Minnesota law, the Sourcewell Board of Directors has authorized a Cooperative Purchasing Program designed to provide Participating Entities with access to competitively awarded cooperative purchasing agreements. To facilitate the Program, Sourcewell has awarded Supplier this cooperative purchasing Master Agreement following a competitive procurement process intended to meet compliance standards in accordance with Minnesota law and the requirements contained herein.
- 2) **Intent.** The intent of this Master Agreement is to define the roles of Sourcewell, Supplier, and Participating Entity as it relates to Sourcewell's Cooperative Purchasing Program.
- 3) **Participating Entity Access.** Sourcewell's Cooperative Purchasing Program Master Agreements are available to eligible public agencies (Participating Entities). A Participating Entity's authority to access Sourcewell's Cooperative Purchasing Program is determined through the laws of its respective jurisdiction.
- 4) **Supplier Access.** The Included Solutions offered under this Agreement may be made available to any Participating Entity. Supplier understands that a Participating Entity's use of this Agreement is at the Participating Entity's sole convenience. Supplier will educate its sales and service forces about Sourcewell eligibility requirements and required documentation. Supplier will be responsible for ensuring sales are with Participating Entities.

- 5) **Term.** This Agreement is effective upon the date of the final signature below. The term of this Agreement is four (4) years from the effective date. The Agreement expires at 11:59 P.M. Central Time on November 1, 2028, unless it is cancelled or extended as defined in this Agreement.
- a) **Extensions.** Sourcewell and Supplier may agree to up to three (3) additional one-year extensions beyond the original four-year term. The total possible length of this Agreement will be seven (7) years from the effective date.
- b) **Exceptional Circumstances.** Sourcewell retains the right to consider additional extensions as required under exceptional circumstances, subject to Supplier's agreement to such extension, subject to Supplier's agreement to such extension.
- 6) **Survival of Terms.** Notwithstanding the termination of this Agreement, the obligations of this Agreement will continue through the performance period of any transaction entered between Supplier and any Participating Entity before the termination date.
- 7) **Scope.** Supplier is awarded a Master Agreement to provide the solutions identified in RFP #080824 to Participating Entities. In Scope solutions include:
- a. HVAC, IAQ, geothermal, and water heating or treatment infrastructure, equipment, components, products, parts, and related technology;
- b. Sensors, smart controls, thermostats, gauges, system automation, integration equipment, monitoring equipment, software, or management products and technology; and;
- c. Services complementary to the offering of the solutions described in Sections 1. a. and b. above, including installation, maintenance, repair, refurbishment, replacement, system upgrades, efficiency measurement, energy saving performance contracting, emergency or short-term HVAC equipment rental, assessment, integration, training, support, and customization.
- 8) **Included Solutions.** Supplier's Proposal to the above referenced RFP is incorporated into this Master Agreement. Only those Solutions included within Supplier's Proposal and within Scope (Included Solutions) are included within the Agreement and may be offered to Participating Entities.
- 9) **Indefinite Quantity.** This Master Agreement defines an indefinite quantity of sales to eligible Participating Entities.
- 10) **Pricing.** Pricing information (including Pricing and Delivery and Pricing Offered tables) for all Included Solutions within Supplier's Proposal is incorporated into this Master Agreement.
- 11) **Not to Exceed Pricing.** Suppliers may not exceed the prices listed in the current Pricing List on file with Sourcewell when offering Included Solutions to Participating Entities. Participating Entities may request adjustments to pricing directly from Supplier during the negotiation and execution of any transaction.
- 12) **Reserved.**

080824-JHN

Signed by:

By: C0FD2A139D06489...
Jeremy Schwartz
Title: Chief Procurement Officer
Date: 11/26/2024 | 3:20 PM CST

DocuSigned by:

By: 70B27D85DF1C41E...
Paul Duncan
Title: Director HVAC Installation
Date: 11/26/2024 | 1:06 PM PST

RFP 080824 - HVAC Systems with Related Products and Services

Vendor Details

Company Name: Johnson Controls, Inc.
Address: 5757 N. Green Bay Ave
P.O. Box 591
Milwaukee, Wisconsin 53201
Contact: Tom Staves
Email: thomas.staves@jci.com
Phone: 443-676-8813
HST#: 39-0380010

Submission Details

Created On: Monday July 08, 2024 14:13:23
Submitted On: Thursday August 08, 2024 09:20:05
Submitted By: Brett Herolt
Email: brett.a.herolt@jci.com
Transaction #: d5b05f1c-f4dc-42c6-8fd5-baa009a15c98
Submitter's IP Address: 136.226.3.75

Vendor Ethics Disclosure Form Has Been Requested



File #: PW-P-0013-26

Agenda Date: 7/7/2026

Agenda #: 9.A.

AWARDING RESOLUTION ISSUED TO
TYLER TECHNOLOGIES, INC.
FOR THE TYLER MUNIS CLOUD BASED CUSTOMER INFORMATION/UTILITY BILLING SYSTEM
SOFTWARE AS A SERVICE (SAAS)
FOR PUBLIC WORKS
(CONTRACT TOTAL AMOUNT \$150,000)

WHEREAS, the County of DuPage by virtue of its power set forth in the Counties Code (55 ILCS 5/1-1001 *et seq.*) is authorized to enter into this Agreement; and

WHEREAS, pursuant to the Governmental Joint Purchasing Act (30 ILCS 525/2), the County is authorized to enter into a Joint Purchasing Agreement for the Tyler Munis Cloud Based Customer Information/Utility Billing System Software as a Service (SaaS); and

WHEREAS, pursuant to Intergovernmental Agreement between the County of DuPage and the Sourcwell Contract #060624-TTI, the County of DuPage will contract with Tyler Technologies, Inc.; and

WHEREAS, the Public Works Committee recommends County Board approval for the issuance of a contract to Tyler Technologies, Inc., FOR the Tyler Munis Cloud Based Customer Information/Utility Billing System Software as a Service (SaaS), for the period of October 1, 2026 through September 30, 2028, for Public Works.

NOW, THEREFORE BE IT RESOLVED, that County contract, covering said for the Tyler Munis Cloud Based Customer Information/Utility Billing System Software as a Service (SaaS), for the period of October 1, 2026 through September 30, 2028, for Public Works, be, and it is hereby approved for issuance of a contract by the Procurement Division to Tyler Technologies, Inc., P.O. Box 203556, Dallas, Texas, 75320-3556, for a contract total amount not to exceed \$150,000, per contract pursuant to the Sourcwell Contract # 060624-TTI.

Enacted and approved this 14th day of July, 2026 at Wheaton, Illinois.

DEBORAH A. CONROY, CHAIR
DU PAGE COUNTY BOARD

Attest: _____
JEAN KACZMAREK, COUNTY CLERK



Procurement Review Comprehensive Checklist
 Procurement Services Division
 This form must accompany all Purchase Order Requisitions

SECTION 1: DESCRIPTION			
<i>General Tracking</i>		<i>Contract Terms</i>	
FILE ID#:	RFP, BID, QUOTE OR RENEWAL #:	INITIAL TERM WITH RENEWALS: OTHER	INITIAL TERM TOTAL COST: \$150,000.00
COMMITTEE: PUBLIC WORKS	TARGET COMMITTEE DATE: 07/07/2026	PROMPT FOR RENEWAL:	CONTRACT TOTAL COST WITH ALL RENEWALS: \$375,000.00
	CURRENT TERM TOTAL COST: \$150,000.00	MAX LENGTH WITH ALL RENEWALS: FOUR YEARS	CURRENT TERM PERIOD: INITIAL TERM
<i>Vendor Information</i>		<i>Department Information</i>	
VENDOR: Tyler Technologies, Inc.	VENDOR #: 27738	DEPT: Public Works	DEPT CONTACT NAME: Stan Spera
VENDOR CONTACT: Gary Dube	VENDOR CONTACT PHONE: 207-518-4130	DEPT CONTACT PHONE #: 630-985-7400	DEPT CONTACT EMAIL: stanley.spera@dupagecounty.gov
VENDOR CONTACT EMAIL: gary.dube@tylertech.com	VENDOR WEBSITE:	DEPT REQ #:	
<i>Overview</i>			
DESCRIPTION Identify scope of work, item(s) being purchased, total cost and type of procurement (i.e., lowest bid, RFP, renewal, sole source, etc.). Recommendation for the approval to Tyler Technologies, Inc. for continued SaaS services in correlation to the Public Works cloud based customer information/utility billing system for the period of October 1, 2026 to September 30, 2028, for a contract total not to exceed \$150,000, based of sourcewell contract #060624-TTI.			
JUSTIFICATION Summarize why this procurement is necessary and what objectives will be accomplished DuPage County Public Works has had great success with the implementation and continual usage of the Tyler Munis cloud based customer information/utility billing system. The Public Works Department recommends continuing to work with Tyler Technologies for this SaaS, as it has improved operational efficiencies within the department.			

SECTION 2: DECISION MEMO REQUIREMENTS
DECISION MEMO NOT REQUIRED Select an item from the following dropdown menu to identify why a Decision Memo (Section 3) is not required.
DECISION MEMO REQUIRED Select an item from the following dropdown menu to identify why a Decision Memo (Section 3) is required. COOPERATIVE (DPC2-352), GOVERNMENT JOINT PURCHASING ACT (30ILCS525) OR GSA SCHEDULE PRICING

SECTION 3: DECISION MEMO	
STRATEGIC IMPACT	Select an item from the following dropdown menu of County's strategic priorities that this action will most impact. CUSTOMER SERVICE
SOURCE SELECTION	Describe method used to select source. Tyler Technologies was awarded through Sourcewell under Contract #060624-TTI.
RECOMMENDATION AND TWO ALTERNATIVES	Describe staff recommendation and provide justification. Identify at least 2 other options to accomplish this request, including status quo, (i.e., take no action). 1. Recommended to award contract to Tyler Technologies for Tyler Munis Cloud Based Customer Information/Utility Billing System. 2. Do not approve contract and go out to bid. Not recommended due to implementation timeline of a new software being 24-36 months. 3. Do not approve purchase at this time. Not recommended due to the impact on DuPage County's nearly 40,000 customers.

SECTION 4: SOLE SOURCE MEMO/JUSTIFICATION

JUSTIFICATION	Select an item from the following dropdown menu to justify why this is a sole source procurement.
NECESSITY AND UNIQUE FEATURES	Describe the product or services that are not available from other vendors. Explain necessary and unique features or services. Attach letters from manufacturer, letters from distributor, warranties, licenses, or patents as needed. Be specific.
MARKET TESTING	List and describe the last time the market has been tested on the applicability of the sole source. If it has not been tested over the last 12 months, explain why not.
AVAILABILITY	Describe steps taken to verify that these features are not available elsewhere. Included a detailed list of all products or services by brand/manufacturer examined and include names, phone numbers, and emails of people contacted.

SECTION 5: Purchase Requisition Information

<i>Send Purchase Order To:</i>		<i>Send Invoices To:</i>	
Vendor: Tyler Technologies, Inc.	Vendor#: 27738	Dept: Public Works	Division: Public Works
Attn: Gary Dube	Email: gary.dube@tylertech.com	Attn: Magda	Email: pwaccountspayable@dupagecount y.gov
Address: P.O. Box 203556	City: Dallas	Address: 7900 S. Rt 53	City: Woodridge
State: TX	Zip: 75320-3556	State: IL	Zip: 60517
Phone: 207-518-4130	Fax:	Phone: 630-985-7400	Fax:
<i>Send Payments To:</i>		<i>Ship to:</i>	
Vendor: Same As Above	Vendor#: Same As Above	Dept: Same As Above	Division: Same As Above
Attn:	Email:	Attn:	Email:
Address:	City:	Address:	City:
State:	Zip:	State:	Zip:
Phone:	Fax:	Phone:	Fax:
Shipping		Contract Dates	
Payment Terms: PER 50 ILCS 505/1	FOB: Destination	Contract Start Date (PO25): Oct 1, 2026	Contract End Date (PO25): Sep 30, 2028
Contract Administrator (PO25): Drew Cormican			

Purchase Requisition Line Details

LN	Qty	UOM	Item Detail (Product #)	Description	FY	Company	AU	Acct Code	Sub-Accts/ Activity Code	Unit Price	Extension
1	1	EA		Tyler Munis Cloud Saas		2000	2665	53807		150,000.00	150,000.00
<i>FY is required, assure the correct FY is selected.</i>										Requisition Total	\$ 150,000.00

<i>Comments</i>	
HEADER COMMENTS	Provide comments for P020 and P025.
SPECIAL INSTRUCTIONS	Provide comments for Buyer or Approver (not for P020 and P025). Comments will not appear on PO.
INTERNAL NOTES	Provide comments for department internal use (not for P020 and P025). Comments will not appear on PO.
APPROVALS	Department Head signature approval for procurements under \$15,000. Procurement Officer Approval for ETSB.

The following documents have been attached: W-9 Vendor Ethics Disclosure Statement



SOFTWARE AS A SERVICE AGREEMENT

This Software as a Service Agreement is made between Tyler Technologies, Inc. and Client.

WHEREAS, Client is a member of Sourcewell ("Sourcewell") under member number 3182;

WHEREAS, Tyler participated in the competitive bid process in response to Sourcewell RFP #060624 by submitting a proposal, on which Sourcewell awarded Tyler a Sourcewell contract, numbered 060624-TTI (hereinafter, the "Sourcewell Contract");

WHEREAS, documentation of the Sourcewell competitive bid process, as well as Tyler's contract with and pricing information for Sourcewell is available at <https://www.sourcewell-mn.gov/cooperative-purchasing/060624-TTI>; and

WHEREAS, Client desires to purchase off the Sourcewell Contract to procure certain software functionality indicated in the Investment Summary from Tyler, which Tyler agrees to deliver pursuant to the Sourcewell Contract and under the terms and conditions set forth below.

WHEREAS, Client selected Tyler to provide certain products and services set forth in the Investment Summary, including providing Client with access to Tyler's proprietary software products, and Tyler desires to provide such products and services under the terms of this Agreement;

NOW THEREFORE, in consideration of the foregoing and of the mutual covenants and promises set forth in this Agreement, Tyler and Client agree as follows:

SECTION A - DEFINITIONS

- **"Agreement"** means this Software as a Services Agreement.
- **"Business Travel Policy"** means our business travel policy. A copy of our current Business Travel Policy is attached as Schedule 1 to Exhibit B.
- **"Client"** means DuPage County, IL.
- **"Data"** means your data necessary to utilize the Tyler Software.
- **"Data Storage Capacity"** means the contracted amount of storage capacity for your Data identified in the Investment Summary.

- **"Defect"** means a failure of the Tyler Software to substantially conform to the functional descriptions set forth in our written proposal to you, or their functional equivalent. Future functionality may be updated, modified, or otherwise enhanced through our maintenance and support services, and the governing functional descriptions for such future functionality will be set forth in our then-current Documentation.
- **"Defined Users"** means the number of users that are authorized to use the Saas Services. The Defined Users for the Agreement are as identified in the Investment Summary.
- **"Developer"** means a third party who owns the intellectual property rights to Third Party Software.
- **"Documentation"** means any online or written documentation related to the use or functionality of the Tyler Software that we provide or otherwise make available to you, including instructions, user guides, manuals and other training or self-help documentation.
- **"Effective Date"** means the date on which your authorized representative signs the Agreement.
- **"Force Majeure"** means an event beyond the reasonable control of you or us, including, without limitation, governmental action, war, riot or civil commotion, fire, natural disaster, or any other cause that could not with reasonable diligence be foreseen or prevented by you or us.
- **"Investment Summary"** means the agreed upon cost proposal for the products and services attached as Exhibit A.
- **"Invoicing and Payment Policy"** means the invoicing and payment policy. A copy of our current Invoicing and Payment Policy is attached as Exhibit B.
- **"Saas Fees"** means the fees for the Saas Services identified in the Investment Summary.
- **"Saas Services"** means software as a service consisting of system administration, system management, and system monitoring activities that Tyler performs for the Tyler Software, and includes the right to access and use the Tyler Software, receive maintenance and support on the Tyler Software, including Downtime resolution under the terms of the SLA, and Data storage and archiving. Saas Services do not include support of an operating system or hardware, support outside of our normal business hours, or training, consulting or other professional services.
- **"SLA"** means the service level agreement. A copy of our current SLA is attached hereto as Exhibit C.
- **"Support Call Process"** means the support call process applicable to all of our customers who have licensed the Tyler Software. A copy of our current Support Call Process is attached as Schedule 1 to Exhibit C.
- **"Third Party Terms"** means, if any, the end user license agreement(s) or similar terms for the Third Party Software, as applicable.
- **"Third Party Hardware"** means the third party hardware, if any, identified in the Investment Summary.
- **"Third Party Products"** means the Third Party Software and Third Party Hardware.
- **"Third Party Software"** means the third party software, if any, identified in the

Investment Summary.

- **"Tyler"** means Tyler Technologies, Inc., a Delaware corporation.
- **"Tyler Software"** means our proprietary software, including any integrations, custom modifications, and/or other related interfaces identified in the Investment Summary and licensed by us to you through this Agreement.
- **"we", "us", "our" and similar terms mean Tyler.**
- **"you" and similar terms mean Client.**

SECTION B- SAAS SERVICES

1. Rights Granted. We grant to you the non-exclusive, non-assignable limited right to use the Saas Services solely for your internal business purposes for the number of Defined Users only. The Tyler Software will be made available to you according to the terms of the SLA. You acknowledge that we have no delivery obligations and we will not ship copies of the Tyler Software as part of the Saas Services. You may use the Saas Services to access updates and enhancements to the Tyler Software, as further described in Section C(8).
2. SaaS Fees. You agree to pay us the SaaS Fees. Those amounts are payable in accordance with our Invoicing and Payment Policy. The SaaS Fees are based on the number of Defined Users and amount of Data Storage Capacity. You may add additional users or additional data storage capacity on the terms set forth in Section H(1). In the event you regularly and/or meaningfully exceed the Defined Users or Data Storage Capacity, we reserve the right to charge you additional fees commensurate with the overage(s).
3. Ownership.
 - 3.1 We retain all ownership and intellectual property rights to the Saas Services, the Tyler Software, and anything developed by us under this Agreement. You do not acquire under this Agreement any license to use the Tyler Software in excess of the scope and/or duration of the Saas Services.
 - 3.2 The Documentation is licensed to you and may be used and copied by your employees for internal, non-commercial reference purposes only.
 - 3.3 You retain all ownership and intellectual property rights to the Data. You expressly recognize that except to the extent necessary to carry out our obligations contained in this Agreement, we do not create or endorse any Data used in connection with the Saas Services.
4. Restrictions. You may not: (a) make the Tyler Software or Documentation resulting from the Saas Services available in any manner to any third party for use in the third party's business operations; (b) modify, make derivative works of, disassemble, reverse compile, or reverse engineer any part of the Saas Services; (c) access or use the Saas Services in order to build or support, and/or assist a third party in building or supporting, products or services competitive to us; or (d) license, sell, rent, lease, transfer, assign, distribute,

display, host, outsource, disclose, permit timesharing or service bureau use, or otherwise commercially exploit or make the Saas Services, Tyler Software, or Documentation available to any third party other than as expressly permitted by this Agreement.

5. Software Warranty. We warrant that the Tyler Software will perform without Defects during the term of this Agreement. If the Tyler Software does not perform as warranted, we will use all reasonable efforts, consistent with industry standards, to cure the Defect in accordance with the maintenance and support process set forth in Section C(S), below, the SLA and our then current Support Call Process.

6. SaaS Services.
 - 6.1 Our SaaS Services are audited at least yearly in accordance with the AICPA's Statement on Standards for Attestation Engagements ("SSAE") No. 21. We have attained, and will maintain, SOC 1 and SOC 2 compliance, or its equivalent, for so long as you are timely paying for SaaS Services. Upon execution of a mutually agreeable Non-Disclosure Agreement ("NDA"), we will provide you with a summary of our compliance report(s) or its equivalent. Every year thereafter, for so long as the NDA is in effect and in which you make a written request, we will provide that same information.

 - 6.2 You will be hosted on shared hardware in a Tyler data center or in a third party datacenter selected by Tyler, but in a database dedicated to you, which is inaccessible to our other customers.

 - 6.3 We have fully-redundant telecommunications access, electrical power, and the required hardware to provide access to the Tyler Software in the event of a disaster or component failure. In the event any of your Data has been lost or damaged due to an act or omission of Tyler or its subcontractors or due to a defect in Tyler's software, we will use best commercial efforts to restore all the Data on servers in accordance with the architectural design's capabilities and with the goal of minimizing any Data loss as greatly as possible. In no case shall the recovery point objective ("RPO") exceed a maximum of twenty-four (24) hours from declaration of disaster. For purposes of this subsection, RPO represents the maximum tolerable period during which your Data may be lost, measured in relation to a disaster we declare, said declaration will not be unreasonably withheld.

 - 6.4 In the event we declare a disaster, our Recovery Time Objective ("RTO") is twenty-four (24) hours. For purposes of this subsection, RTO represents the amount of time, after we declare a disaster, within which your access to the Tyler Software must be restored.

 - 6.5 We conduct annual penetration testing of either the production network and/or web

application to be performed. We will maintain industry standard intrusion detection and prevention systems to monitor malicious activity in the network and to log and block any such activity. We will provide you with a written or electronic record of the actions taken by us in the event that any unauthorized access to your database(s) is detected as a result of our security protocols. We will undertake an additional security audit, on terms and timing to be mutually agreed to by the parties, at your written request. You may not attempt to bypass or subvert security restrictions in the SaaS Services or environments related to the Tyler Software.

Unauthorized attempts to access files, passwords or other confidential information, and unauthorized vulnerability and penetration test scanning of our network and systems (hosted or otherwise) is prohibited without the prior written approval of our IT Security Officer.

6.6 We test our disaster recovery plan on an annual basis. Our standard test is not client-specific. Should you request a client-specific disaster recovery test, we will work with you to schedule and execute such a test on a mutually agreeable schedule. At your written request, we will provide test results to you within a commercially reasonable timeframe after receipt of the request.

6.7 We will be responsible for importing back-up and verifying that you can log-in. You will be responsible for running reports and testing critical processes to verify the returned Data.

6.8 We provide secure Data transmission paths between each of your workstations and our servers.

6.9 For at least the past twelve (12) years, all of our employees have undergone criminal background checks prior to hire. All employees sign our confidentiality agreement and security policies. Our data centers are accessible only by authorized personnel with a unique key entry. All other visitors must be signed in and accompanied by authorized personnel. Entry attempts to the data center are regularly audited by internal staff and external auditors to ensure no unauthorized access.

6.10 Where applicable with respect to our applications that take or process card payment data, we are responsible for the security of cardholder data that we possess, including functions relating to storing, processing, and transmitting of the cardholder data and affirm that, as of the Effective Date, we comply with applicable requirements to be considered PCI DSS compliant and have performed the necessary steps to validate compliance with the PCI DSS. We agree to supply the current status of our PCI DSS compliance program in the form of an official Attestation of Compliance, which can be found at <https://www.tylertech.com/about-us/compliance>, and in the event of any change in our status, will comply with

applicable notice **requirements**.

SECTION C- OTHER PROFESSIONAL SERVICES

1. Other Professional Services. We will provide you the various implementation-related services itemized in the Investment Summary and described in our industry standard implementation plan. We will finalize that documentation with you upon execution of this Agreement.
2. Professional Services Fees. You agree to pay us the professional services fees in the amounts set forth in the Investment Summary. Those amounts are payable in accordance with our Invoicing and Payment Policy. You acknowledge that the fees stated in the Investment Summary are good-faith estimates of the amount of time and materials required for your implementation. We will bill you the actual fees incurred based on the in-scope services provided to you. Any discrepancies in the total values set forth in the Investment Summary will be resolved by multiplying the applicable hourly rate by the quoted hours.
3. Additional Services. The Investment Summary contains the scope of services and related costs (including programming and/or interface estimates) required for the project based on our understanding of the specifications you supplied. If additional work is required, or if you use or request additional services, we will provide you with an addendum or change order, as applicable, outlining the costs for the additional work. The price quotes in the addendum or change order will be valid for thirty (30) days from the date of the quote.
4. Cancellation. If travel is required, we will make all reasonable efforts to schedule travel for our personnel, including arranging travel reservations, at least two (2) weeks in advance of commitments. Therefore, if you cancel services less than two (2) weeks in advance (other than for Force Majeure or breach by us), you will be liable for all (a) non-refundable expenses incurred by us on your behalf, and (b) daily fees associated with cancelled professional services if we are unable to reassign our personnel. We will make all reasonable efforts to reassign personnel in the event you cancel within two (2) weeks of scheduled commitments.
5. Services Warranty. We will perform the services in a professional, workmanlike manner, consistent with industry standards. In the event we provide services that do not conform to this warranty, we will re-perform such services at no additional cost to you.
6. Site Access and Requirements. At no cost to us, you agree to provide us with full and free access to your personnel, facilities, and equipment as may be reasonably necessary for us to provide implementation services, subject to any reasonable security protocols or other written policies provided to us as of the Effective Date, and thereafter as mutually agreed to by you and us.
7. Client Assistance. You acknowledge that the implementation of the Tyler Software is a cooperative process requiring the time and resources of your personnel. You agree to

use all reasonable efforts to cooperate with and assist us as may be reasonably required to meet the agreed upon project deadlines and other milestones for implementation. This cooperation includes at least working with us to schedule the implementation-related services outlined in this Agreement. We will not be liable for failure to meet any deadlines and milestones when such failure is due to Force Majeure or to the failure by your personnel to provide such cooperation and assistance (either through action or omission).

8. Maintenance and Support. For so long as you timely pay your Saas Fees according to the Invoicing and Payment Policy, then in addition to the terms set forth in the SLA and the Support Call Process, we will:

8.1 perform our maintenance and support obligations in a professional, good, and workmanlike manner, consistent with industry standards, to resolve Defects in the Tyler Software (limited to the then-current version and the immediately prior version);

8.2 provide telephone support during our established support hours;

8.3 maintain personnel that are sufficiently trained to be familiar with the Tyler Software and Third Party Software, if any, in order to provide maintenance and support services;

8.4 make available to you all major and minor releases to the Tyler Software (including updates and enhancements) that we make generally available without additional charge to customers who have a maintenance and support agreement in effect; and

8.5 provide non-Defect resolution support of prior releases of the Tyler Software in accordance with our then-current release life cycle policy.

We will use all reasonable efforts to perform support services remotely. Currently, we use a third-party secure unattended connectivity tool called Bomgar, as well as GotoAssist by Citrix. Therefore, you agree to maintain a high-speed internet connection capable of connecting us to your PCs and server(s). You agree to provide us with a login account and local administrative privileges as we may reasonably require to perform remote services. We will, at our option, use the secure connection to assist with proper diagnosis and resolution, subject to any reasonably applicable security protocols. If we cannot resolve a support issue remotely, we may be required to provide onsite services. In such event, we will be responsible for our travel expenses, unless it is determined that the reason onsite support was required was a reason outside our control. Either way, you agree to provide us with full and free access to the Tyler Software, working space, adequate facilities within a reasonable distance from the equipment, and use of machines, attachments, features, or other equipment reasonably necessary for us to provide the maintenance and support services, all at no charge to us. We strongly recommend that you also maintain your VPN for backup connectivity purposes.

For the avoidance of doubt, SaaS Fees do not include the following services: (a) onsite support (unless Tyler cannot remotely correct a Defect in the Tyler Software, as set forth above); (b) application design; (c) other consulting services; or (d) support outside our normal business hours as listed in our then-current Support Call Process. Requested services such as those outlined in this section will be billed to you on a time and materials basis at our then current rates. You must request those services with at least one (1) weeks' advance notice.

SECTION D-THIRD PARTY PRODUCTS

1. Third Party Hardware. We will sell, deliver, and install onsite the Third Party Hardware, if you have purchased any, for the price set forth in the Investment Summary. Those amounts are payable in accordance with our Invoicing and Payment Policy.
2. Third Party Software. As part of the SaaS Services, you will receive access to the Third Party Software and related documentation for internal business purposes only. Your rights to the Third Party Software will be governed by the Third Party Terms.
3. Third Party Products Warranties.
 - 3.1 We are authorized by each Developer to grant access to the Third Party Software.
 - 3.2 The Third Party Hardware will be new and unused, and upon payment in full, you will receive free and clear title to the Third Party Hardware.
 - 3.3 You acknowledge that we are not the manufacturer of the Third Party Products. We do not warrant or guarantee the performance of the Third Party Products. However, we grant and pass through to you any warranty that we may receive from the Developer or supplier of the Third Party Products.

SECTION E - INVOICING AND PAYMENT; INVOICE DISPUTES

1. Invoicing and Payment. We will invoice you the SaaS Fees and fees for other professional services in the Investment Summary per our Invoicing and Payment Policy, subject to Section E(2).
2. Invoice Disputes. If you believe any delivered software or service does not conform to the warranties in this Agreement, you will provide us with written notice within 45 days of your receipt of the applicable invoice. The written notice must contain reasonable detail of the issues you contend are in dispute so that we can confirm the issue and respond to your notice with either a justification of the invoice, an adjustment to the invoice, or a proposal addressing the issues presented in your notice. We will work with you as may be necessary to develop an action plan that outlines reasonable steps to be taken by each of us to resolve any issues presented in your notice.
You may withhold payment of the amount(s) actually in dispute, and only those amounts, until we complete the action items outlined in the plan. If we are unable to complete the action items outlined in the action plan because of your failure to complete the items agreed to be done by you, then you will remit full payment of the invoice. We reserve the right to suspend delivery of all SaaS Services, including maintenance and support services, if you fail to pay an invoice not disputed as described above within fifteen (15) days of notice of our intent to do so. Nothing in this provision shall be construed to require you to violate applicable provisions of the Government Prompt Payment Act.

SECTION F - TERM AND TERMINATION

1. Term. The initial term of this Agreement is two (2) years, commencing October 1, 2026, unless earlier terminated as set forth below. Upon expiration of the initial term, this Agreement may be renewed for successive one (1) year renewal terms by mutual agreement of the parties at our then-current SaaS Fees. Client may indicate its agreement to renewal terms by timely payment of a Tyler invoice of annual fees for the renewal term. Your right to access or use the Tyler Software and the SaaS Services will terminate at the end of this Agreement and any renewal(s) thereto.
2. Termination. This Agreement may be terminated as set forth below. In the event of termination, you will pay us for all undisputed fees and expenses related to the software, products, and/or services you have received, or we have incurred or delivered, prior to the effective date of termination. Disputed fees and expenses in all terminations other than your termination for cause must have been submitted as invoice disputes in accordance with Section E(2).

- 2.1 Failure to Pay Saas Fees. You acknowledge that continued access to the Saas Services is contingent upon your timely payment of Saas Fees. If you fail to timely pay the Saas Fees, we may discontinue the Saas Services and deny your access to the Tyler Software. We may also terminate this Agreement if you don't cure such failure to pay within forty-five (45) days of receiving written notice of our intent to terminate.
- 2.2 For Cause. If you believe we have materially breached this Agreement, you will invoke the Dispute Resolution clause set forth in Section H(3). You may terminate this Agreement for cause in the event we do not cure, or create a mutually agreeable action plan to address, a material breach of this Agreement within the thirty (30) day window set forth in Section H(3).
- 2.3 For Convenience. You may terminate the contract for convenience on thirty (30) days' prior written notice. Upon termination, you shall remit payment for all products and services delivered to you and all expenses incurred by us prior through the effective date of termination. You will not be entitled to a refund or offset of previously paid license and other fees.
- 2.4 Lack of Appropriations. If you should not appropriate or otherwise make available funds sufficient to utilize the Saas Services, you may unilaterally terminate this Agreement upon thirty (30) days written notice to us. You will not be entitled to a refund or offset of previously paid, but unused Saas Fees. You agree not to use termination for lack of appropriations as a substitute for termination for convenience.
- 2.5 Fees for Termination without Cause during Initial Term. If you terminate this Agreement during the initial term for any reason other than cause, or lack of appropriations, or if we terminate this Agreement during the initial term for your failure to pay Saas Fees, you shall pay us the following early termination fees:
- a. if you terminate during the first year of the initial term, 100% of the Saas Fees through the date of termination plus 15% of the Saas Fees then due for the remainder of the initial term;
 - b. if you terminate during the second year of the initial term, 100% of the Saas Fees through the date of termination plus 10% of the Saas Fees then due for the remainder of the initial term; and
 - c. if you terminate after the second year of the initial term, 100% of the Saas Fees through the date of termination plus 5% of the Saas Fees then due for the remainder of the initial term.
3. Delivery of Documentation and Data. If and as requested by Client, Tyler shall reasonably deliver to Client, and/or the replacement provider, non-proprietary documentation and data related to Tyler's provision of the Services, including, at a minimum, Client Data in a standard Microsoft SQL backup, any completed deliverables, partially completed deliverables related to the terminated portion of the Agreement, and any plans, working papers, forms, documentation formats, etc. reasonably necessary for understanding of the deliverables of services and other documents provided to it by Client, held by Tyler including its employees and agents and made generally available to its clients.

SECTION G - INDEMNIFICATION, LIMITATION OF LIABILITY AND INSURANCE

1. Intellectual Property Infringement Indemnification.

- 1.1 We will defend you against any third party claim(s) that the Tyler Software or Documentation infringes that third party's patent, copyright, or trademark, or misappropriates its trade secrets, and will pay the amount of any resulting adverse final judgment (or settlement to which we consent). You must notify us promptly in writing of the claim and give us sole control over its defense or settlement. The foregoing notwithstanding, we will obtain your consent before agreeing to any settlement requiring payment by you. You agree to provide us with reasonable assistance, cooperation, and information in defending the claim at our expense.
- 1.2 Our obligations under this Section G(l) will not apply to the extent the claim or adverse final judgment is based on your use of the Tyler Software in contradiction of this Agreement, including with non-licensed third parties, or your willful infringement.
- 1.3 If we receive information concerning an infringement or misappropriation claim related to the Tyler Software, we may, at our expense and without obligation to do so, either: (a) procure for you the right to continue its use; (b) modify it to make it non-infringing; or (c) replace it with a functional equivalent, in which case you will stop running the allegedly infringing Tyler Software immediately. Alternatively, we may decide to litigate the claim to judgment, in which case you may continue to use the Tyler Software consistent with the terms of this Agreement.
- 1.4 If an infringement or misappropriation claim is fully litigated and your use of the Tyler Software is enjoined by a court of competent jurisdiction, in addition to paying any adverse final judgment (or settlement to which we consent), we will, at our option, either: (a) procure the right to continue its use; (b) modify it to make it non-infringing; or (c) replace it with a functional equivalent. This section provides your exclusive remedy for third party copyright, patent, or trademark infringement and trade secret misappropriation claims.

2. General Indemnification.

- 2.1 We will indemnify and hold harmless you and your agents, officials, and employees from and against any and all third-party claims, losses, liabilities, damages, costs, and expenses (including reasonable attorney's fees and costs) for (a) personal injury or property damage, except if such personal injury or property damage is caused directly by your willful and wanton conduct; or (b) our violation of PCI-DSS requirements or a law applicable to our performance under this Agreement. You must notify us promptly in writing of the claim and give us sole control over its defense or settlement. The foregoing notwithstanding, we will obtain your consent before agreeing to any settlement requiring payment by you. You agree to provide us with reasonable assistance, cooperation, and information in defending the claim at our expense.
- 2.2 To the extent permitted by applicable law, you will indemnify and hold harmless us and our agents, officials, and employees from and against any and all third-party claims, losses, liabilities, damages, costs, and expenses (including reasonable attorney's fees and costs) for personal injury or property damage to the extent caused by your willful misconduct. We will notify you promptly in writing of the claim and will give you sole control over its defense or settlement. We agree to

provide you with reasonable assistance, cooperation, and information in defending the claim at your expense.

2.3 An attorney designated to represent the County in a legal proceeding may not do so until approved by the State's Attorney and appointed as a Special Assistant State's Attorney if such approval and appointment is required by law.

3. **DISCLAIMER.** EXCEPT FOR THE EXPRESS WARRANTIES PROVIDED IN THIS AGREEMENT AND TO THE MAXIMUM EXTENT PERMITTED BY APPLICABLE LAW, WE HEREBY DISCLAIM ALL OTHER WARRANTIES AND CONDITIONS, WHETHER EXPRESS, IMPLIED, OR STATUTORY, INCLUDING, BUT NOT LIMITED TO, ANY IMPLIED WARRANTIES, DUTIES, OR CONDITIONS OF MERCHANTABILITY OR FITNESS FOR A PARTICULAR PURPOSE.

4. **LIMITATION OF LIABILITY.** EXCEPT AS OTHERWISE EXPRESSLY SET FORTH IN THIS AGREEMENT, OUR LIABILITY FOR DAMAGES ARISING OUT OF THIS AGREEMENT, WHETHER BASED ON A THEORY OF CONTRACT OR TORT, INCLUDING NEGLIGENCE AND STRICT LIABILITY, SHALL BE LIMITED TO YOUR ACTUAL DIRECT DAMAGES, NOT TO EXCEED (A) DURING THE INITIAL TERM, AS SET FORTH IN SECTION F(2), TOTAL FEES PAID AS OF THE TIME OF THE CLAIM; OR (B) DURING ANY RENEWAL TERM, THE THEN-CURRENT ANNUAL SAAS FEES PAYABLE IN THAT RENEWAL TERM. THE PARTIES ACKNOWLEDGE AND AGREE THAT THE PRICES SET FORTH IN THIS AGREEMENT ARE SET IN ELIANCE UPON THIS LIMITATION OF LIABILITY AND TO THE MAXIMUM EXTENT ALLOWED UNDER APPLICABLE LAW, THE EXCLUSION OF CERTAIN DAMAGES, AND EACH SHALL APPLY REGARDLESS OF THE FAILURE OF AN ESSENTIAL PURPOSE OF ANY REMEDY. THE FOREGOING LIMITATION OF LIABILITY SHALL NOT APPLY TO CLAIMS THAT ARE SUBJECT TO SECTIONS G(1) AND G(2).

5. **EXCLUSION OF CERTAIN DAMAGES.**

5.1 TO THE MAXIMUM EXTENT PERMITTED BY APPLICABLE LAW, IN NO EVENT SHALL WE BE LIABLE FOR ANY SPECIAL, INCIDENTAL, PUNITIVE, INDIRECT, OR CONSEQUENTIAL DAMAGES WHATSOEVER, EVEN IF WE HAVE BEEN ADVISED OF THE POSSIBILITY OF SUCH DAMAGES.

5.2 The Client does not waive, by these indemnity requirements, any defenses or protections under the Local Government and Governmental Employees Tort Liability Act (745 ILCS 10/1, et seq.) or otherwise available to it under the law. In no event shall the Client indemnify Tyler for damages for which the Client is otherwise immune under the law.

6. **Insurance.** We must obtain, for the Contract term and any extension of it, insurance issued by a company or companies qualified to do business in the State of Illinois with an A.M. Best Rating of at least A- and provide the County with a Certificate of Insurance 15 days before the start of the project, and thereafter annually for contracts/ projects that will last more than one year. Insurance in the following types and amounts is necessary and/or where applicable:

Workers Compensation (Coverage A) and Employers Liability (Coverage B)

Workers Compensation Insurance covering all liability of Tyler arising under the Worker's Compensation Act and Worker's Occupational Disease Act at limits in accordance with the laws of the State of Illinois.

Employers' Liability Insurance shall be maintained to respond to claims for damages because of bodily injury, occupational sickness, or disease or death of the Tyler's employees, with limits listed below:

- a) Each Accident \$1,000,000
- b) Disease-Policy Limit \$1,000,000
- c) Disease-Each Employee
\$1,000,000

Commercial General Liability Insurance

In a broad form on an occurrence basis shall be maintained, to include, but not be limited to, coverage for property damage, bodily injury (including death), personal injury and advertising injury in the following coverage forms where exposure exists:

- Premises and Operations
- Independent Contractors
- Products/Completed Operations
- Liability assumed under an Insured Contract/ Contractual Liability
- Personal Injury and Advertising Injury

With limits of liability not less than:

- \$2,000,000 Each Occurrence
- \$ 2,000,000 Products-Completed Operations
- \$2,000,000 Personal and Advertising injury limit
- \$ 2,000,000 General aggregate.

Tyler may use a combination of primary and excess/Umbrella policy/policies to satisfy the limits of liability required.

Automobile Liability Insurance (if applicable)

Automobile liability insurance shall be maintained to respond to claims for damages because of bodily injury, death of a person, or property damage arising out of ownership, maintenance, or use of a motor vehicle. This policy shall be written to cover any auto whether owned, leased, hired, or borrowed.

Tyler's auto liability insurance, as required above, shall be written with limits of insurance not less than the following:

- \$ 1,000,000 Combined single Limit (Each Accident)

Professional Liability - Cyber Liability (if applicable)

Cyber Liability Insurance for property damage to electronic information and/or data; first and third party risks associated with e-business, internet, etc., with limits of insurance not less than the following:

- \$ 1,000,000 per claim limit and in the aggregate

Technology Errors and Omissions (if applicable)

Tyler's Software Developer and/or IT Consultant for the plans, including developing and implementing technology for DuPage County, or of the project, shall be written with limits of insurance not less than the following:

- \$ 1,000,000 per claim limit

Technology Errors and Omissions coverage may be included under Tyler's Professional Liability with a total combined aggregate limit of \$2,000,000.

Excess/ Umbrella Liability (if applicable)

Tyler's Excess/ Umbrella liability insurance shall be written with the umbrella follow form and outline the underlying coverage, limits of insurance will be based on size of project:

\$ 2,000,000 per occurrence limit

Liability Insurance Conditions

Tyler agrees that with respect to the above required insurance:

- a) Tyler's insurance shall be primary in the event of a claim, except of Professional Liability and Workers' Compensation and Employers Liability.
- b) Tyler agrees that with respect to the above required CGL and Auto insurance, shall be included as additional insured, including its agents, officers, and employees.;
- c) Tyler agrees to provide written notice in the event any policies are cancelled or materially changed;
- d) DuPage County shall be provided with Certificates of Insurance and blanket endorsements evidencing the above required insurance, prior to commencement of services under this Agreement and thereafter with certificates evidencing renewals or replacements of said policies of insurance upon the expiration or cancellation of any such policies.
- e) Any hard copies of said Notices and Certificates of Insurance shall be provided to:

DuPage County Procurement

421 N. County Farm Rd.

Wheaton, Illinois 60187

Attn: Valerie Calvente, Chief Procurement Officer

SECTION H - SECURITY AND CONFIDENTIALITY

L Security Incident or Data Breach Notification.

- a. Security Incident Response: Tyler may need to communicate with outside parties regarding a security incident, which may include contacting law enforcement, fielding media inquiries, and seeking external expertise as defined by law. Discussing security incidents with the Client should be handled on an urgent as-needed basis, as part of Tyler's communication and mitigation processes as mutually agreed, defined by law or as otherwise required by this Agreement.
- b. Breach Reporting Requirements: If Tyler has actual knowledge of a confirmed Data Breach that affects the security of any Client Data that is subject to applicable Data Breach notification law, Tyler shall (1) promptly notify the appropriate Client Identified Contact in accordance with applicable law, (2) take commercially reasonable measures to address the Data Breach in a timely manner.

This section only applies when a Data Breach occurs with respect to Personal Data and/or Non-Public Data within the possession or control of Tyler and related to service provided under this Agreement. Nothing contained herein, however, shall be construed to limit or restrict Client from contacting Tyler to obtain information relating to a Data Breach that has not affected the systems or services utilized by the Client and to obtain confirmation that such Data Breach has not impacted those systems or servers utilized by the Client.

SECTION I - GENERAL TERMS AND CONDITIONS

1. Additional Products and Services. You may purchase additional products and services at the rates set forth in the Investment Summary for twelve (12) months from the Effective Date by executing a mutually agreed addendum. If no rate is provided in the Investment Summary, or those twelve (12) months have expired, you may purchase additional products and services at our then-current list price, also by executing a mutually agreed addendum. The terms of this Agreement will control any such additional purchase(s), unless otherwise specifically provided in the addendum.
2. Optional Items. Pricing for any listed optional products and services in the Investment Summary will be valid for twelve (12) months from the Effective Date.
3. Dispute Resolution. Disputes arising out of, or relating to, this Agreement, other than invoice disputes subject to Section E(2), shall first be discussed by the relevant Project Managers. Unless a different time period is agreed to by the Project Managers, the Project Managers will have ten (10) business days to resolve the dispute, such ten-day period being measured from the date the non-disputing party received the notice of dispute. If the dispute cannot be resolved within that timeframe, it shall be referred to the County Purchasing Agent and the Chief Operating Officer of the appropriate division of Tyler, or their designee(s) (the "Intermediary Dispute Level"). If the dispute cannot be resolved at that Intermediary Dispute Level, the venue for all disputes will be exclusively in the circuit court for the Eighteenth Judicial Circuit in DuPage County, Illinois or the Federal District Court serving DuPage County and that Illinois law will control. Any negotiations pursuant to this Section are confidential and shall be treated as compromise and settlement negotiations for purposes of the applicable rules of evidence. Nothing in this section shall prevent County or Tyler from seeking necessary injunctive and/or equitable relief during the dispute resolution procedures.
4. Specific Performance and Injunctive Relief. Each party agrees that monetary damages may not be an adequate remedy for a breach of this Agreement and that, in such event, the damaged party may be entitled to specific performance or other injunctive or equitable relief.
5. Taxes. The fees in the Investment Summary do not include any taxes, including, without limitation, sales, use, or excise tax. If you are a tax-exempt entity, you agree to provide us with a tax-exempt certificate. Otherwise, we will pay all applicable taxes to the proper authorities and you will reimburse us for such taxes. If you have a valid direct-pay permit, you agree to provide us with a copy. For clarity, we are responsible for paying our income taxes, both federal and state, as applicable, arising from our performance of this Agreement. As of the Effective Date, the County is exempt from paying certain Illinois State taxes.
6. Nondiscrimination. We will not discriminate against any person employed or applying for employment concerning the performance of our responsibilities under this Agreement. This discrimination prohibition will apply to all matters of initial employment, tenure, and terms of employment, or otherwise with respect to any matter directly or indirectly relating to employment **concerning race, color, religion, national origin, age, sex, sexual orientation, ancestry, disability that** is unrelated to the individual's ability to perform the duties of a particular job or position, height, weight, marital status, or political affiliation. We will post, where appropriate, all notices related to nondiscrimination as may be required by applicable law.
7. E-Verify. We have complied, and will comply, with the E-Verify procedures administered by

the U.S. Citizenship and Immigration Services Verification Division for all of our employees assigned to your project.

8. Subcontractors. We will not subcontract any services under this Agreement without your prior written consent, not to be unreasonably withheld.
9. Binding Effect; No Assignment. This Agreement shall be binding on, and shall be for the benefit of, either your or our successor(s) or permitted assign(s). Neither party may assign this Agreement without the prior written consent of the other party; provided, however, your consent is not required for an assignment by us as a result of a corporate reorganization, merger, acquisition, or purchase of substantially all of our assets.
10. Force Majeure. Except for your payment obligations, neither party will be liable for delays in performing its obligations under this Agreement to the extent that the delay is caused by Force Majeure; provided, however, that within ten (10) business days of the Force Majeure event, the party whose performance is delayed provides the other party with written notice explaining the cause and extent thereof, as well as a request for a reasonable time extension equal to the estimated duration of the Force Majeure event.
11. No Intended Third Party Beneficiaries. This Agreement is entered into solely for the benefit of you and us. No third party will be deemed a beneficiary of this Agreement, and no third party will have the right to make any claim or assert any right under this Agreement. This provision does not affect the rights of third parties under any Third Party Terms.
12. Entire Agreement: Amendment. This Agreement represent the entire agreement between you and us with respect to the subject matter hereof, and supersedes any prior agreements, understandings, and representations, whether written, oral, expressed, implied, or statutory. Purchase orders submitted by you, if any, are for your internal administrative purposes only, and the terms and conditions contained in those purchase orders will have no force or effect. This Agreement may only be modified by a written amendment signed by an authorized representative of each party.
13. Severability. If any term or provision of this Agreement is held invalid or unenforceable, the remainder of this Agreement will be considered valid and enforceable to the fullest extent permitted by law.
14. No Waiver. In the event that the terms and conditions of this Agreement are not strictly enforced by either party, such non-enforcement will not act as or be deemed to act as a waiver or modification of this Agreement, nor will such non-enforcement prevent such party from enforcing each and every term of this Agreement thereafter.
15. Independent Contractor. We are an independent contractor for all purposes under this Agreement.
16. Notices. All notices or communications required or permitted as a part of this Agreement, such as notice of an alleged material breach for a termination for cause or a dispute that must be submitted to dispute resolution, must be in writing and will be deemed delivered upon the earlier of the following: (a) actual receipt by the receiving party; (b) upon receipt by sender of a certified mail, return receipt signed by an employee or agent of the receiving party; (c) upon receipt by sender of proof of email delivery; or (d) if not actually received, five (5) days after deposit with the United States Postal Service authorized mail center with proper postage (certified mail, return receipt requested) affixed and addressed to the other party at the address set forth on the signature page hereto or such other address as the party

may have designated by proper notice. The consequences for the failure to receive a notice due to improper notification by the intended receiving party of a change in address will be borne by the intended receiving party.

17. Client Lists. You agree that we may identify you by name in client lists, marketing presentations, and promotional materials.
18. Confidentiality. DuPage County is subject to the Illinois Freedom of Information Act. Both parties recognize that their respective employees and agents, in the course of performance of this Agreement, may be exposed to confidential information and that disclosure of such information could violate rights to private individuals and entities, including the parties. Confidential information is nonpublic information that a reasonable person would believe to be confidential and includes, without limitation, personal identifying information (*e.g.*, social security numbers) and trade secrets, each as defined by applicable state law. Each party agrees that it will not disclose any confidential information of the other party and further agrees to take all reasonable and appropriate action to prevent such disclosure by its employees or agents. The confidentiality covenants contained herein will survive the termination or cancellation of this Agreement. This obligation of confidentiality will not apply to information that:
 - (a) is in the public domain, either at the time of disclosure or afterwards, except by breach of this Agreement by a party or its employees or agents;
 - (b) a party can establish by reasonable proof was in that party's possession at the time of initial **disclosure**;
 - (c) a party receives from a third party who has a right to disclose it to the receiving party; or
 - (d) is the subject of a legitimate disclosure request under the open records laws or similar applicable public disclosure laws governing this Agreement; provided, however, that in the event you receive an open records or other similar applicable request, you will give us prompt notice and otherwise perform the functions required by applicable law.
19. Business License. In the event a local business license is required for us to perform services hereunder, you will promptly notify us and provide us with the necessary paperwork and/or contact information so that we may timely obtain such license.
20. Governing Law. This Agreement will be governed by and construed in accordance with the laws of your state of domicile, without regard to its rules on conflicts of law.
21. Multiple Originals and Authorized Signatures. This Agreement may be executed in multiple originals, any of which will be independently treated as an original document. Any electronic, faxed, scanned, photocopied, or similarly reproduced signature on this Agreement or any amendment hereto will be deemed an original signature and will be fully enforceable as if an original signature. Each party represents to the other that the signatory set forth below is duly authorized to bind that party to this Agreement.
22. Cooperative Procurement. To the maximum extent permitted by applicable law, we agree that this Agreement may be used as a cooperative procurement vehicle by eligible jurisdictions. We reserve the right to negotiate and customize the terms and conditions set forth herein, including but not limited to pricing, to the scope and circumstances of that cooperative procurement.

23. Contract Documents & Order of Precedence. This Agreement includes the following exhibits:

- Exhibit A Investment Summary
- Exhibit B Invoicing and Payment Policy
 Schedule 1: Business Travel
- Exhibit C Policy Service Level Agreement
 Schedule 1: Support Call Process

IN WITNESS WHEREOF, a duly authorized representative of each party has executed this Agreement as of the date(s) set forth below.

Tyler Technologies, Inc.

DuPage County, IL

By: Erik Graney

By: _____

Name: Erik Graney

Name: _____

Title: Senior Corporate Attorney

Title: _____

Date: 06/25/26

Date: _____

Address for Notices:

Tyler Technologies, Inc.
One Tyler Drive
Yarmouth, ME 04096
Attention: Chief Legal Officer

Address for Notices:

DuPage County
421 N County Farm Road
Wheaton, IL 60187-3992
Attention: _____



Exhibit A
Investment Summary
Annual SaaS Fees

51816	DUPAGE COUNTY, IL	MUNASP-MAR	MUNIS APPLICATION SERVICES - MUNIS ANALYTICS & REPORTING	10.1.26 - 9.30.27	\$2,475.90
51816	DUPAGE COUNTY, IL	MUNASP-GL	MUNIS APPLICATION SERVICES - ACCTG/GL/BUDGET/AP		\$6,696.90
51816	DUPAGE COUNTY, IL	MUNASP-IS-D-TCM-SE	MUNIS APPLICATIONS SERVICES - TYLER CONTENT MANAGER SE		\$7,468.65
51816	DUPAGE COUNTY, IL	MUNASP-DOCTFP-D	MUNIS APPLICATIONS SERVICES - TYLER FORMS PROCESSING INCLUDING GODOCS		\$4,899.30
51816	DUPAGE COUNTY, IL	MUNASP-GB	MUNIS APPLICATION SERVICES - GENERAL BILLING		\$3,484.95
51816	DUPAGE COUNTY, IL	MUNASP-AR	MUNIS APPLICATION SERVICES - ACCOUNTS RECEIVABLE		\$5,477.85
51816	DUPAGE COUNTY, IL	MUNASP-UBCIS	MUNIS APPLICATION SERVICES - UTILITY BILLING CIS		\$30,023.70
51816	DUPAGE COUNTY, IL	MUNASP-UBI	MUNIS APPLICATION SERVICES - UTILITY BILLING INTERFACE		\$7,394.10
					\$67,921.35
				Quarterly	\$16,980.34



Exhibit B
Invoicing and Payment Policy

We will provide you with the software and services set forth in the Investment Summary of the Agreement. Capitalized terms not otherwise defined will have the meaning assigned to such terms in the Agreement.

Invoicing: We will invoice you for the applicable software and services in the Investment Summary as set forth below. Your rights to dispute any invoice are set forth in the Agreement.

1. **SaaS Fees.**

1.1 Your annual SaaS fees for year one (1) of the initial term are set forth in Exhibit A. Tyler shall invoice Client on a quarterly basis. Annual SaaS fees for year two (2) renewal of the renewal term, shall be invoiced at a five percent (5%) increase over the previous year's SaaS fees. Subsequent annual SaaS fees will be at our then-current rates.

Payment. Payment for undisputed invoices is due within sixty (60) days of the invoice date. We prefer to receive payments electronically. Our electronic payment information is:

Bank: Wells Fargo Bank, N.A.
420 Montgomery
San Francisco, CA 94104
ABA: 121000248
Account: 4124302472
Beneficiary: Tyler Technologies, Inc. – Operating



Exhibit B
Schedule 1
Business Travel Policy

1. Air Travel

A. Reservations & Tickets

Tyler's Travel Management Company (TMC) will provide an employee with a direct flight within two hours before or after the requested departure time, assuming that flight does not add more than three hours to the employee's total trip duration and the fare is within \$100 (each way) of the lowest logical fare. If a net savings of \$200 or more (each way) is possible through a connecting flight that is within two hours before or after the requested departure time and that does not add more than three hours to the employee's total trip duration, the connecting flight should be accepted.

Employees are encouraged to make advanced reservations to take full advantage of discount opportunities. Employees should use all reasonable efforts to make travel arrangements at least two (2) weeks in advance of commitments. A seven (7) day advance booking requirement is mandatory. When booking less than seven (7) days in advance, management approval will be required.

Except in the case of international travel where a segment of continuous air travel is six (6) or more consecutive hours in length, only economy or coach class seating is reimbursable. Employees shall not be reimbursed for "Basic Economy Fares" because these fares are non-refundable and have many restrictions that outweigh the cost-savings.

B. Baggage Fees

Reimbursement of personal baggage charges are based on trip duration as follows:

- Up to five (5) days = one (1) checked bag
- Six (6) or more days = two (2) checked bags

Baggage fees for sports equipment are not reimbursable.

2. Ground Transportation

A. Private Automobile

Mileage Allowance – Business use of an employee’s private automobile will be reimbursed at the current IRS allowable rate, plus out of pocket costs for tolls and parking. Mileage will be calculated by using the employee's office as the starting and ending point, in compliance with IRS regulations. Employees who have been designated a home office should calculate miles from their home.

B. Rental Car

Employees are authorized to rent cars only in conjunction with air travel when cost, convenience, and the specific situation reasonably require their use. When renting a car for Tyler business, employees should select a “mid-size” or “intermediate” car. “Full” size cars may be rented when three or more employees are traveling together. Tyler carries leased vehicle coverage for business car rentals; except for employees traveling to Alaska and internationally (excluding Canada), additional insurance on the rental agreement should be declined.

C. Public Transportation

Taxi or airport limousine services may be considered when traveling in and around cities or to and from airports when less expensive means of transportation are unavailable or impractical. The actual fare plus a reasonable tip (15-18%) are reimbursable. In the case of a free hotel shuttle to the airport, tips are included in the per diem rates and will not be reimbursed separately.

D. Parking & Tolls

When parking at the airport, employees must use longer term parking areas that are measured in days as opposed to hours. Park and fly options located near some airports may also be used. For extended trips that would result in excessive parking charges, public transportation to/from the airport should be considered. Tolls will be reimbursed when receipts are presented.

3. Lodging

Tyler’s TMC will select hotel chains that are well established, reasonable in price, and conveniently located in relation to the traveler's work assignment. Typical hotel chains include Courtyard, Fairfield Inn, Hampton Inn, and Holiday Inn Express. If the employee has a discount rate with a local hotel, the hotel reservation should note that discount and the employee should confirm the lower rate with the hotel upon arrival. Employee memberships in travel clubs such as AAA should be noted in their travel profiles so that the employee can take advantage of any lower club rates.

“No shows” or cancellation fees are not reimbursable if the employee does not comply with the hotel’s cancellation policy.

Tips for maids and other hotel staff are included in the per diem rate and are not reimbursed separately.

Employees are not authorized to reserve non-traditional short-term lodging, such as Airbnb, VRBO, and HomeAway. Employees who elect to make such reservations shall not be reimbursed.

4. Meals and Incidental Expenses

Employee meals and incidental expenses while on travel status within the continental U.S. are in accordance with the federal per diem rates published by the General Services Administration. Incidental expenses include tips to maids, hotel staff, and shuttle drivers and other minor travel expenses. Per diem rates are available at www.gsa.gov/perdiem.

Per diem for Alaska, Hawaii, U.S. protectorates and international destinations are provided separately by the Department of Defense and will be determined as required.

A. Overnight Travel

For each full day of travel, all three meals are reimbursable. Per diems on the first and last day of a trip are governed as set forth below.

Departure Day

Depart before 12:00 noon	Lunch and dinner
Depart after 12:00 noon	Dinner

Return Day

Return before 12:00 noon	Breakfast
Return between 12:00 noon & 7:00 p.m.	Breakfast and lunch
Return after 7:00 p.m.*	Breakfast, lunch and dinner

*7:00 p.m. is defined as direct travel time and does not include time taken to stop for dinner.

The reimbursement rates for individual meals are calculated as a percentage of the full day per diem as follows:

Breakfast	15%
Lunch	25%
Dinner	60%

B. Same Day Travel

Employees traveling at least 100 miles to a site and returning in the same day are eligible to claim lunch on an expense report. Employees on same day travel status are eligible to claim dinner in the event they return home after 7:00 p.m.*

*7:00 p.m. is defined as direct travel time and does not include time taken to stop for dinner.

5. Internet Access – Hotels and Airports

Employees who travel may need to access their e-mail at night. Many hotels provide free high speed internet access and Tyler employees are encouraged to use such hotels whenever possible. If an employee's hotel charges for internet access it is reimbursable up to \$10.00 per day. Charges for internet access at airports are not reimbursable.

6. International Travel

All international flights with the exception of flights between the U.S. and Canada should be reserved through TMC using the "lowest practical coach fare" with the exception of flights that are six (6) or more consecutive hours in length. In such event, the next available seating class above coach shall be reimbursed.

When required to travel internationally for business, employees shall be reimbursed for photo fees, application fees, and execution fees when obtaining a new passport book, but fees related to passport renewals are not reimbursable. Visa application and legal fees, entry taxes and departure taxes are reimbursable.

The cost of vaccinations that are either required for travel to specific countries or suggested by the U.S. Department of Health & Human Services for travel to specific countries, is reimbursable.

Section 4, Meals & Incidental Expenses, and Section 2.b., Rental Car, shall apply to this section.



Exhibit C

SERVICE LEVEL AGREEMENT

I. Agreement Overview

This SLA operates in conjunction with, and does not supersede or replace any part of, the Agreement. It outlines the information technology service levels that we will provide to you to ensure the availability of the application services that you have requested us to provide. All other support services are documented in the Support Call Process.

II. **Definitions.** Except as defined below, all defined terms have the meaning set forth in the Agreement.

Attainment: The percentage of time the Tyler Software is available during a calendar quarter, with percentages rounded to the nearest whole number.

Client Error Incident: Any service unavailability resulting from your applications, content or equipment, or the acts or omissions of any of your service users or third-party providers over whom we exercise no control.

Downtime: Those minutes during which the Tyler Software is not available for your use. Downtime does not include those instances in which only a Defect is present.

Service Availability: The total number of minutes in a calendar quarter that the Tyler Software is capable of receiving, processing, and responding to requests, excluding maintenance windows, Client Error Incidents and Force Majeure.

III. **Service Availability**

The Service Availability of the Tyler Software is intended to be 24/7/365. We set Service Availability goals and measures whether we have met those goals by tracking Attainment.

a. Your Responsibilities

Whenever you experience Downtime, you must make a support call according to the procedures outlined in the Support Call Process. You will receive a support incident number.

You must document, in writing, all Downtime that you have experienced during a calendar quarter. You must deliver such documentation to us within 30 days of a quarter's end.

The documentation you provide must evidence the Downtime clearly and convincingly. It must include, for example, the support incident number(s) and the date, time and duration of the Downtime(s).

b. Our Responsibilities

When our support team receives a call from you that Downtime has occurred or is occurring, we will work with you to identify the cause of the Downtime (including whether it may be the result of a Client Error Incident or Force Majeure). We will also work with you to resume normal operations.

Upon timely receipt of your Downtime report, we will compare that report to our own outage logs and

support tickets to confirm that Downtime for which we were responsible indeed occurred.

We will respond to your Downtime report within 30 day(s) of receipt. To the extent we have confirmed Downtime for which we are responsible, we will provide you with the relief set forth below.

c. Client Relief

When a Service Availability goal is not met due to confirmed Downtime, we will provide you with relief that corresponds to the percentage amount by which that goal was not achieved, as set forth in the Client Relief Schedule below.

Notwithstanding the above, the total amount of all relief that would be due under this SLA per quarter will not exceed 5% of one quarter of the then-current SaaS Fee. The total credits confirmed by us in one or more quarters of a billing cycle will be applied to the SaaS Fee for the next billing cycle. Issuing of such credit does not relieve us of our obligations under the Agreement to correct the problem which created the service interruption.

Every quarter, we will compare confirmed Downtime to Service Availability. In the event actual Attainment does not meet the targeted Attainment, the following Client relief will apply, on a quarterly basis:

Targeted Attainment	Actual Attainment	Client Relief
100%	98-99%	Remedial action will be taken.
100%	95-97%	4% credit of fee for affected calendar quarter will be posted to next billing cycle
100%	<95%	5% credit of fee for affected calendar quarter will be posted to next billing cycle

You may request a report from us that documents the preceding quarter's Service Availability, Downtime, any remedial actions that have been/will be taken, and any credits that may be issued.

IV. Applicability

The commitments set forth in this SLA do not apply during maintenance windows, Client Error Incidents, and Force Majeure.

We perform maintenance during limited windows that are historically known to be reliably low-traffic times. If and when maintenance is predicted to occur during periods of higher traffic, we will provide advance notice of those windows and will coordinate to the greatest extent possible with you.

V. Force Majeure

You will not hold us responsible for not meeting service levels outlined in this SLA to the extent any failure to do so is caused by Force Majeure. In the event of Force Majeure, we will file with you a signed request that said failure be excused. That writing will at least include the essential details and circumstances supporting our request for relief pursuant to this Section. You will not unreasonably withhold its acceptance of such a request.



Exhibit C
Schedule 1
Support Call Process

Support Channels

Tyler Technologies, Inc. provides the following channels of software support:

- (1) Tyler Community – an on-line resource, Tyler Community provides a venue for all Tyler clients with current maintenance agreements to collaborate with one another, share best practices and resources, and access documentation.
- (2) On-line submission (portal) – for less urgent and functionality-based questions, users may create unlimited support incidents through the customer relationship management portal available at the Tyler Technologies website.
- (3) Email – for less urgent situations, users may submit unlimited emails directly to the software support group.
- (4) Telephone – for urgent or complex questions, users receive toll-free, unlimited telephone software support.

Support Resources

A number of additional resources are available to provide a comprehensive and complete support experience:

- (1) Tyler Website – www.tylertech.com – for accessing client tools and other information including support contact information.
- (2) Tyler Community – available through login, Tyler Community provides a venue for clients to support one another and share best practices and resources.
- (3) Knowledgebase – A fully searchable depository of thousands of documents related to procedures, best practices, release information, and job aides.
- (4) Program Updates – where development activity is made available for client consumption

Support Availability

Tyler Technologies support is available during the local business hours of 8 AM to 5 PM (Monday – Friday) across four US time zones (Pacific, Mountain, Central and Eastern). Clients may receive coverage across these time zones. Tyler’s holiday schedule is outlined below. There will be no support coverage on these days.

New Year’s Day	Thanksgiving Day
Memorial Day	Day after Thanksgiving
Independence Day	Christmas Day
Labor Day	

Issue Handling

Incident Tracking

Every support incident is logged into Tyler’s Customer Relationship Management System and given a unique incident number. This system tracks the history of each incident. The incident tracking number is used to track and reference open issues when clients contact support. Clients may track incidents, using the incident number, through the portal at Tyler’s website or by calling software support directly.

Incident Priority

Each incident is assigned a priority number, which corresponds to the client’s needs and deadlines. The client is responsible for reasonably setting the priority of the incident per the chart below. This chart is not intended to address every type of support incident, and certain “characteristics” may or may not apply depending on whether the Tyler software has been deployed on customer infrastructure or the Tyler cloud. The goal is to help guide the client towards clearly understanding and communicating the importance of the issue and to describe generally expected responses and resolutions.

Priority Level	Characteristics of Support Incident	Resolution Targets
1 Critical	Support incident that causes (a) complete application failure or application unavailability; (b) application failure or unavailability in one or more of the client’s remote location; or (c) systemic loss of multiple essential system functions.	Tyler shall provide an initial response to Priority Level 1 incidents within one (1) business hour of receipt of the support incident. Tyler shall use commercially reasonable efforts to resolve such support incidents or provide a circumvention procedure within one (1) business day. For non-hosted customers, Tyler’s responsibility for lost or corrupted Data is limited to assisting the client in restoring its last available database.
2 High	Support incident that causes (a) repeated, consistent failure of essential functionality affecting more than one user or (b) loss or corruption of Data.	Tyler shall provide an initial response to Priority Level 2 incidents within four (4) business hours of receipt of the support incident. Tyler shall use commercially reasonable efforts to resolve such support incidents or provide a circumvention procedure within ten (10) business days. For non-hosted customers, Tyler’s responsibility for loss or corrupted Data is limited to assisting the client in restoring its last available database.
3 Medium	Priority Level 1 incident with an existing circumvention procedure, or a Priority Level 2 incident that affects only one user or for which there is an existing circumvention procedure.	Tyler shall provide an initial response to Priority Level 3 incidents within one (1) business day of receipt of the support incident. Tyler shall use commercially reasonable efforts to resolve such support incidents without the need for a circumvention procedure with the next published maintenance update or service pack. For non-hosted customers, Tyler’s responsibility for lost or corrupted Data is limited to assisting the client in restoring its last available database.
4 Non-critical	Support incident that causes failure of non-essential functionality or a cosmetic or other issue that does not qualify as any other Priority Level.	Tyler shall provide an initial response to Priority Level 4 incidents within two (2) business days. Tyler shall use commercially reasonable efforts to resolve such support incidents, as well as cosmetic issues, with a future version release.

Incident Escalation

Tyler Technology's software support consists of four levels of personnel:

- (1) Level 1: front-line representatives
- (2) Level 2: more senior in their support role, they assist front-line representatives and take on escalated issues
- (3) Level 3: assist in incident escalations and specialized client issues
- (4) Level 4: responsible for the management of support teams for either a single product or a product group

If a client feels they are not receiving the service needed, they may contact the appropriate Software Support Manager. After receiving the incident tracking number, the manager will follow up on the open issue and determine the necessary action to meet the client's needs.

On occasion, the priority or immediacy of a software support incident may change after initiation. Tyler encourages clients to communicate the level of urgency or priority of software support issues so that we can respond appropriately. A software support incident can be escalated by any of the following methods:

- (1) Telephone – for immediate response, call toll-free to either escalate an incident's priority or to escalate an issue through management channels as described above.
- (2) Email – clients can send an email to software support in order to escalate the priority of an issue
- (3) On-line Support Incident Portal – clients can also escalate the priority of an issue by logging into the client incident portal and referencing the appropriate incident tracking number.

Remote Support Tool

Some support calls require further analysis of the client's database, process or setup to diagnose a problem or to assist with a question. Tyler will, at its discretion, use an industry-standard remote support tool. Support is able to quickly connect to the client's desktop and view the site's setup, diagnose problems, or assist with screen navigation. More information about the remote support tool Tyler uses is available upon request.





DuPage County IL Tyler Software as a Service Agreement 062426_Tyler

Final Audit Report

2026-06-25

Created:	2026-06-24
By:	Amanda Andreine (amanda.andreine@tylertech.com)
Status:	Signed
Transaction ID:	CBJCHBCAABAAD9Cz4GMNuZGg4VeQLefn9YEnK6PnfRpC

"DuPage County IL Tyler Software as a Service Agreement 062426_Tyler" History

-  Document created by Amanda Andreine (amanda.andreine@tylertech.com)
2026-06-24 - 3:54:14 PM GMT- IP address: 162.10.127.41
-  Document emailed to Erik Graney (erik.graney@tylertech.com) for signature
2026-06-24 - 4:06:18 PM GMT
-  Email viewed by Erik Graney (erik.graney@tylertech.com)
2026-06-25 - 4:53:02 PM GMT- IP address: 163.116.247.61
-  Document e-signed by Erik Graney (erik.graney@tylertech.com)
Signature Date: 2026-06-25 - 4:54:16 PM GMT - Time Source: server- IP address: 163.116.247.61 - Signature Appearance Selected: IMAGE
-  Agreement completed.
2026-06-25 - 4:54:16 PM GMT

Tyler Technologies - Pricing Summary Discount **		Discount on then-current Software Licenses pricing for initial term	Discount on then-current Software related SaaS Fees for initial term	Discount on Renewal Contracts/ SaaS Flips/Tyler Migrations	Additional Details
Proprietary & Confidential					
Public Administration					
ERP					
	Enterprise ERP <i>powered by Munis</i>	10%	10%	-	
	ERP Pro <i>powered by InCode</i>	10%	10%	-	
	School ERP Pro <i>powered by Infinite Visions</i>	10%	10%	-	
	New World ERP	10%	10%	-	
	Time & Attendance <i>powered by Executime</i>	10%	10%	-	
	Time & Attendance <i>powered by Executime Clocks & Hardware***</i>	-	-	-	
	Enterprise Service Requests (previously Tyler 311)	10%	10%	-	
	Cashiering	10%	10%	-	
	Content Manager	10%	10%	-	
	Meeting Manager	10%	10%	-	
	ACFR Statement Builder	10%	10%	-	
	Payments*	-	-	-	
	Notify	10%	10%	-	
	Data & Insights solutions for ERP	-	10%	-	
	Absence & Substitute	10%	10%	-	
	Priority Based Budgeting	-	10%	-	
	Cornerstone****	-	-	-	
	DebtBook****	-	-	-	
	Envisio****	-	-	-	
	KOA Hills****	-	-	-	
	Patternstream	-	-	-	
	Polco****	-	-	-	
	Snaplogic****	-	10%	-	
Civic Services					
	Enterprise Permitting & Licensing <i>powered by EnerGov</i>	10%	10%	-	
	Enterprise Permitting <i>powered by MyGov</i>	10%	10%	-	
	Enterprise Environmental Health	10%	10%	-	
	Enterprise Permitting & Licensing and Environmental Health Extensions (including Civic Access)	10%	10%	-	
	Cashiering	10%	10%	-	
	Enterprise Service Requests (Tyler 311)	10%	10%	-	
	Fire Prevention Mobile (powered by MobileEyes)	10%	10%	-	
	My Civic	10%	10%	-	
	Enterprise Asset Management (Tyler EAM)	10%	10%	-	
	Data & Insights Solutions for Civic Services	-	10%	-	
	Recreation Dynamics	-	10%	-	
	Payments*	-	-	-	
	DigEPlan****	-	-	-	

	Tyler Technologies - Pricing Summary Discount ** Proprietary & Confidential	Discount on then-current Software Licenses pricing for initial term	Discount on then-current Software related SaaS Fees for initial term	Discount on Renewal Contracts/ SaaS Flips/Tyler Migrations	Additional Details
Property & Recording					
	A&T CAMA Standard	10%	10%	-	
	Assessment Administration	10%	10%	-	
	CAMA	10%	10%	-	
	Additional Modules:				
	Inquiry & Appeals Tracking	10%	10%	-	
	Public Access	10%	10%	-	
	SmartFile	10%	10%	-	
	Field Mobile	10%	10%	-	
	Delinquent Tax	10%	10%	-	
	Inquiry & Appeals Tracking	10%	10%	-	
	Records Management <i>powered by Eagle</i>	10%	10%	-	
	Assessment & Tax Plus <i>powered by Eagle</i>	10%	10%	-	
	Content Manager	10%	10%	-	
	TrueRoll****	-	-	-	
Schools					
	School ERP Pro <i>powered by Infinite Visions</i>	10%	10%	-	
	Versatrans	10%	10%	-	
	Student Transportation <i>powered by Traversa</i>	-	10%	-	
	Student Transportation related Hardware	-	-	-	
	Absence & Substitute	10%	10%	-	
Justice & Public Safety					
Justice					
	Core Enterprise Justice <i>powered by Odyssey</i> Modules	10%	10%	-	
	Enterprise Justice Clerk Edition	10%	10%	-	
	eFile & Serve*	-	10%	-	
	Enterprise Justice Judge Edition	10%	10%	-	
	Enterprise Justice Connectors	10%	10%	-	
	State Specific Functions	10%	10%	-	
	Tyler Mobility	-	10%	-	
	Tyler Mobility Hardware***	-	-	-	
	Enterprise Supervision*	-	10%	-	
	Enterprise Supervision Hardware***	-	-	-	
	Enterprise Supervision Payments*	-	-	-	
	Online Dispute Resolution <i>powered by Modria</i> *	-	10%	-	
	Enterprise Corrections	10%	10%	-	
	Defendant Access*	-	-	-	
	Justice Insights	-	10%	-	
	CJIS Enterprise Data Platform	-	10%	-	
	Virtual Court	-	10%	-	
	Municipal Justice <i>powered by Incode Court</i>	10%	10%	-	
	reSearch*	-	10%	-	
	Electronic Discovery	-	10%	-	
	VendEngine*	-	-	-	
	VendEngine Hardware***	-	-	-	
	Civil Process <i>powered by Softcode</i>	10%	10%	-	
	Electronic Warrants	-	10%	-	
	Enterprise Jury*	10%	10%	-	
	Fusion Stack/Cloud Gavel *, *****	-	10%	-	

	Tyler Technologies - Pricing Summary Discount ** Proprietary & Confidential	Discount on then-current Software Licenses pricing for initial term	Discount on then-current Software related SaaS Fees for initial term	Discount on Renewal Contracts/ SaaS Flips/Tyler Migrations	Additional Details
Public Safety					
	Enterprise Public Safety <i>powered by New World</i>	10%	10%	-	
	Public Safety Pro <i>powered by Incode</i>	10%	10%	-	
	Enforcement Mobile <i>powered by Brazos - Core Licensing</i>	10%	10%	-	
	Enforcement Mobile <i>powered by Brazos - related Hardware</i>	-	-	-	
	Data Collect Mobile <i>powered by SceneDoc</i>	-	10%	-	
	Emergency Networking ****	-	10%	-	
Transformative Technology (Tyler One)					
Data & Insights					
	Enterprise Data Platform <i>powered by Socrata</i>	-	5%	-	
Cybersecurity					
	Cybersecurity	-	5%	-	5% discount on services pricing
Platform Technologies					
	Case Management Development Platform <i>powered by Entellitrak</i>	5%	5%	-	Discount included in submitted pricing document
	Versa	5%	-	-	
Payments					
	Payments*	-	-	-	
	Rapid Disbursement Platform*	-	10%	-	10% discount on software only
Notes					
	* No discount for transactional				
	** Tyler will discount then-current software license pricing by 10% and then current SaaS fees for the initial contracted term. Tyler's Socrata SaaS product offerings fees will be discounted by 5% for the initial contracted term. This discount does not extend to services pricing, (implementation focused training, project management, product development, or service subscriptions) software maintenance costs, or hardware. This product listing can expand with additional products that are developed by Tyler and accommodate solicitation scope.				
	***No Discount for Hardware				
	**** Third Party/Partners				



Solicitation Number: RFP #060624

CONTRACT

This Contract is between Sourcewell, 202 12th Street Northeast, P.O. Box 219, Staples, MN 56479 (Sourcewell) and Tyler Technologies, Inc., 5101 Tennyson Pkwy., Plano, TX 75024 (Supplier).

Sourcewell is a State of Minnesota local government unit and service cooperative created under the laws of the State of Minnesota (Minnesota Statutes Section 123A.21) that offers cooperative procurement solutions to government entities. Participation is open to eligible federal, state/province, and municipal governmental entities, higher education, K-12 education, nonprofit, tribal government, and other public entities located in the United States and Canada. Sourcewell issued a public solicitation for Software Solutions and Related Services for Public Sector and Education Administration from which Supplier was awarded a contract in Categories 1, 2, 3, 4, and 5.

Supplier desires to contract with Sourcewell to provide equipment, products, or services to Sourcewell and the entities that access Sourcewell's cooperative purchasing contracts (Participating Entities).

1. TERM OF CONTRACT

A. **EFFECTIVE DATE.** This Contract is effective upon the date of the final signature below.

EXPIRATION DATE AND EXTENSION. This Contract expires October 25, 2028, unless it is cancelled sooner pursuant to Article 22. This Contract allows up to three additional one-year extensions upon the request of Sourcewell and written agreement by Supplier. Sourcewell retains the right to consider additional extensions beyond seven years as required under exceptional circumstances; provided, however, that any additional extension will be upon written agreement by Supplier.

B. **SURVIVAL OF TERMS.** Notwithstanding any expiration or termination of this Contract, all payment obligations incurred prior to expiration or termination will survive, as will the following: Articles 11 through 14 survive the expiration or cancellation of this Contract. All other rights will cease upon expiration or termination of this Contract.

Sourcewell

Tyler Technologies, Inc.

By 
Jeremy Schwartz
Title: Chief Procurement Officer
Date: 11/13/2024 | 4:32 PM CST

B 
Tina Mize
Title: Group General Counsel
Date: 11/13/2024 | 4:27 PM CST



DuPage County
 Finance Department
 Procurement Division
 421 North County Farm Road
 Room 3-400
 Wheaton, Illinois 60187-3978

REQUIRED VENDOR ETHICS DISCLOSURE STATEMENT

Section I: Contact Information

Please complete the contact information below.

BID NUMBER:	No formal Bid, using Sourcewell Contract Number (060624-TTI)
COMPANY NAME:	Tyler Technologies, Inc.
CONTACT PERSON:	Gary Dube
CONTACT EMAIL:	gary.dube@tylertech.com

Section II: Procurement Ordinance Requirements

Every contractor, union, or vendor that is seeking or has previously obtained a contract, change orders to one (1) or more contracts, or two (2) or more individual contracts with the County, shall provide to the Procurement Division a written disclosure of all political campaign contributions made by such contractor, union, or vendor to any incumbent County Board member, County Board chairman, or Countywide elected official whose office the contract to be awarded will benefit within the current and previous calendar year. The contractor, union, or vendor shall update such disclosure annually during the term of a multi-year contract and prior to any change order or renewal requiring approval by the county board. For purposes of this disclosure requirement, "contractor or vendor" includes owners, officers, managers, lobbyists, agents, consultants, bond counsel and underwriters counsel, subcontractors, and corporate entities under the control of the contracting person, and political action committees to which the contracting person has made contributions.

Has the Bidder made contributions as described above?

Yes

No

If "Yes", complete the required information in the table below.

RECIPIENT	DONOR	DESCRIPTION (e.g., cash, type of item, in-kind services, etc.)	AMOUNT/VALUE	DATE MADE

All contractors and vendors who have obtained or are seeking contracts with the County shall disclose the names and contact information of their lobbyists, agents and representatives and all individuals who are or will be having contact with county officers or employees in relation to the contractor bid and shall update such disclosure with any changes that may occur.

Has the Bidder had or will the Bidder have contact with lobbyists, agents, representatives or individuals who are or will be having contact with county officers or employees as described above.

- Yes
- No

If "Yes", list the name, phone number, and email of lobbyists, agents, representatives, and all individuals who are or will be having contact with county officers or employees in the table below.

NAME	PHONE	EMAIL

Section III: Violations

A contractor or vendor that knowingly violates these disclosure requirements is subject to penalties which may include, but are not limited to, the immediate cancellation of the contract and possible disbarment from future County contracts. Continuing and supplemental disclosure is required. The Bidder agrees to update this disclosure form as follows:

- If information changes, within five (5) days of change, or prior to county action, whichever is sooner;
- 30 days prior to the optional renewal of any contract;
- Annual disclosure for multi-year contracts on the anniversary of said contract
- With any request for change order except those issued by the county for administrative adjustments

The full text of the County's Ethics Ordinance is available at:

http://www.dupagecounty.gov/government/county_board/ethics_at_the_county/

The full text of the County's Procurement Ordinance is available at:

https://www.dupagecounty.gov/government/departments/finance/procurement/procurement_ordinance_and_guiding_principles.php

Section IV: Certification

By signing below, the Bidder hereby acknowledges that it has received, read, and understands these requirements, and certifies that the information submitted on this form is true and correct to the best of its knowledge.

Printed Name: Erik Graney

Signature: 

Title: Senior Corporate Attorney

Date: 06/08/26





DuPage IL Required Vendor Ethics Disclosure Statement 060826_Tyler

Final Audit Report

2026-06-08

Created:	2026-06-08
By:	Amanda Andreine (amanda.andreine@tylertech.com)
Status:	Signed
Transaction ID:	CBJCHBCAABAANzayT6zc5CrVHWteNDftZEFekrp_sqw

"DuPage IL Required Vendor Ethics Disclosure Statement 060826_Tyler" History

-  Document created by Amanda Andreine (amanda.andreine@tylertech.com)
2026-06-08 - 7:22:48 PM GMT- IP address: 162.10.127.134
-  Document emailed to Erik Graney (erik.graney@tylertech.com) for signature
2026-06-08 - 7:23:22 PM GMT
-  Email viewed by Erik Graney (erik.graney@tylertech.com)
2026-06-08 - 7:35:28 PM GMT- IP address: 163.116.249.49
-  Document e-signed by Erik Graney (erik.graney@tylertech.com)
Signature Date: 2026-06-08 - 7:36:01 PM GMT - Time Source: server- IP address: 163.116.249.49 - Signature Appearance Selected: IMAGE
-  Agreement completed.
2026-06-08 - 7:36:01 PM GMT



File #: FM-P-0022-26

Agenda Date: 7/7/2026

Agenda #: 9.B.

AWARDING RESOLUTION ISSUED
TO MALCOR ROOFING OF ILLINOIS, INC.
FOR ROOF RESTORATION WORK AT THE SHERIFF'S OFFICE
FOR FACILITIES MANAGEMENT
(CONTRACT AMOUNT NOT TO EXCEED: \$548,784.50)

WHEREAS, pursuant to Intergovernmental Agreement between the County of DuPage and Omnia Partners, the County of DuPage will contract with Malcor Roofing of Illinois, Inc.; and

WHEREAS, the Public Works Committee recommends County Board approval for the issuance of a contract to Malcor Roofing of Illinois, Inc., to provide roof restoration work at the Sheriff's Office, for the period July 14, 2026 through July 13, 2027, for Facilities Management.

NOW, THEREFORE BE IT RESOLVED, that County Contract, covering said, to provide roof restoration work at the Sheriff's Office, for the period July 14, 2026 through July 13, 2027, for Facilities Management, be, and it is hereby approved for issuance of a contract by the Procurement Division to, Malcor Roofing of Illinois, Inc., 1850 Dean Street, St. Charles, IL 60174, for a total contract amount not to exceed \$548,784.50.

Enacted and approved this 14th day of July, 2026 at Wheaton, Illinois.

DEBORAH A. CONROY, CHAIR
DU PAGE COUNTY BOARD

Attest: _____
JEAN KACZMAREK, COUNTY CLERK



Procurement Review Comprehensive Checklist
 Procurement Services Division
 This form must accompany all Purchase Order Requisitions

SECTION 1: DESCRIPTION			
<i>General Tracking</i>		<i>Contract Terms</i>	
FILE ID#: 26-1850	RFP, BID, QUOTE OR RENEWAL #:	INITIAL TERM WITH RENEWALS: OTHER	INITIAL TERM TOTAL COST: \$548,784.50
COMMITTEE: PUBLIC WORKS	TARGET COMMITTEE DATE: 07/07/2026	PROMPT FOR RENEWAL:	CONTRACT TOTAL COST WITH ALL RENEWALS: \$548,784.50
	CURRENT TERM TOTAL COST: \$548,784.50	MAX LENGTH WITH ALL RENEWALS: ONE YEAR	CURRENT TERM PERIOD: INITIAL TERM
<i>Vendor Information</i>		<i>Department Information</i>	
VENDOR: Malcor Roofing of Illinois, Inc.	VENDOR #:	DEPT: Facilities Management	DEPT CONTACT NAME: Brian Rovik
VENDOR CONTACT: Jason Doran	VENDOR CONTACT PHONE: 630-896-6479	DEPT CONTACT PHONE #: 630-407-5705	DEPT CONTACT EMAIL: brian.rovik2@dupagecounty.gov
VENDOR CONTACT EMAIL: jason@malcorroofing.com	VENDOR WEBSITE:	DEPT REQ #:	
<i>Overview</i>			
DESCRIPTION Identify scope of work, item(s) being purchased, total cost and type of procurement (i.e., lowest bid, RFP, renewal, sole source, etc.). Recommendation for the approval of a contract to Malcor Roofing of IL, Inc., for roof restoration work at the Sheriff's Office, for Facilities Management, for the period July 14, 2026, through July 13, 2027, for a total contract amount not to exceed \$548,784.50. Contract pursuant to the Intergovernmental Cooperation Act – OMNIA Partners Contract #R230404.			
JUSTIFICATION Summarize why this procurement is necessary and what objectives will be accomplished A full roof restoration is necessary to protect the integrity of the building envelope, to ensure the facilities remain reliable for proper operation as to not impact the life, health and safety of our employees and the public. The existing roof is nearing the end of its current warranty and by restoring the roof at this time, we do not need to tear off the existing roof system and will seal any of the new penetrations from recent HVAC work. Moisture testing revealed part of the existing insulation is wet after rain events; this contract would repair the damp insulation areas. We are able to apply a two-part, bio-based, polyurethane roof coating system which provides a new 20 year warranty.			

SECTION 2: DECISION MEMO REQUIREMENTS	
DECISION MEMO NOT REQUIRED	Select an item from the following dropdown menu to identify why a Decision Memo (Section 3) is not required.
DECISION MEMO REQUIRED	Select an item from the following dropdown menu to identify why a Decision Memo (Section 3) is required.
COOPERATIVE (DPC2-352), GOVERNMENT JOINT PURCHASING ACT (30ILCS525) OR GSA SCHEDULE PRICING	

SECTION 3: DECISION MEMO	
SOURCE SELECTION	Describe method used to select source. Region 4 ESC through the Omnia Partners received responses from eight (8) vendors to RFP #23-04 for Roofing Products and services. The proposals were evaluated by an evaluation committee. Using the evaluation criteria established in the RFP, the committee elected to enter into negotiations with Weatherproofing Technologies, Inc. (WTI) Region 4 ESC, Omnia Partners and WTI successfully negotiated a contract, Region 4 ESC executed the agreement with a contract effective date of November 1, 2023. Malcor Roofing of Illinois, Inc. is apart of the WTI Contractor Network.
RECOMMENDATION AND TWO ALTERNATIVES	Describe staff recommendation and provide justification. Identify at least 2 other options to accomplish this request, including status quo, (i.e., take no action). 1) Staff recommends securing a contract with Malcor Roofing of Illinois, Inc, for roof restoration work at the Sheriff's Office, for Facilities Management, for the period July 14, 2026, through July 13, 2027, for a total contract amount not to exceed \$548,784.50. Contract pursuant to the Intergovernmental Cooperation Act – OMNIA Partners Contract #R230404. 2) Do not approve a contract and let the roof systems warranties expire and have the roofs fall into disrepair. 3) The other option includes sending the annual contract out to bid which does not guarantee prices will be lower or that the quality of product and service will be equivalent. 4) Staff did review other national-cooperative proposals for this and similar products and this was the most economical choice.

SECTION 4: SOLE SOURCE MEMO/JUSTIFICATION

JUSTIFICATION	Select an item from the following dropdown menu to justify why this is a sole source procurement.
NECESSITY AND UNIQUE FEATURES	Describe the product or services that are not available from other vendors. Explain necessary and unique features or services. Attach letters from manufacturer, letters from distributor, warranties, licenses, or patents as needed. Be specific.
MARKET TESTING	List and describe the last time the market has been tested on the applicability of the sole source. If it has not been tested over the last 12 months, explain why not.
AVAILABILITY	Describe steps taken to verify that these features are not available elsewhere. Included a detailed list of all products or services by brand/manufacturer examined and include names, phone numbers, and emails of people contacted.

SECTION 5: Purchase Requisition Information

<i>Send Purchase Order To:</i>		<i>Send Invoices To:</i>	
Vendor: Malcor Roofing of Illinois, Inc.	Vendor#:	Dept: Facilities Management	Division:
Attn: Jason Doran	Email: jason@malcorroofing.com	Attn:	Email: FMAccountsPayable@dupagecounty.gov
Address: 1850 Dean Street	City: St. Charles	Address: 421 N County Farm Rd.	City: Wheaton
State: IL	Zip: 60174	State: IL	Zip: 60187
Phone: 630-896-6479	Fax:	Phone: 630-407-5700	Fax: 630-407-5701
<i>Send Payments To:</i>		<i>Ship to:</i>	
Vendor: Malcor Roofing of Illinois, Inc.	Vendor#:	Dept: Facilities Management	Division:
Attn: Jason Doran	Email: jason@malcorroofing.com	Attn: Geoff Matteson	Email: Geoffrey.Matteson@dupagecounty.gov
Address: 1850 Dean Street	City: St. Charles	Address: 501 N. County Farm Rd	City: Wheaton
State: IL	Zip: 60174	State: IL	Zip: 60187
Phone: 630-896-6479	Fax:	Phone: 630-407-5681	Fax:
Shipping		Contract Dates	
Payment Terms: PER 50 ILCS 505/1	FOB: Destination	Contract Start Date (PO25): Jul 14, 2026	Contract End Date (PO25): Jul 13, 2027

Purchase Requisition Line Details

LN	Qty	UOM	Item Detail (Product #)	Description	FY	Company	AU	Acct Code	Sub-Accts/Activity Code	Unit Price	Extension
1	1	LO		Roof Restoration	FY26	6000	1220	54010	2600729	498,895.00	498,895.00
2	1	LO		Contingency	FY26	6000	1220	54010	2600729	49,889.50	49,889.50
<i>FY is required, ensure the correct FY is selected.</i>										Requisition Total	\$ 548,784.50

<i>Comments</i>	
HEADER COMMENTS	Provide comments for P020 and P025. Roof restoration work at the Sheriff's Office. Pursuant to the Intergovernmental Cooperation Act – OMNIA Partners Contract #R230404.
SPECIAL INSTRUCTIONS	Provide comments for Buyer or Approver (not for P020 and P025). Comments will not appear on PO. Send PO to Vendor, Cathie Figlewski, Geoff Matteson, Brian Rovik, and Clara Gomez
INTERNAL NOTES	Provide comments for department internal use (not for P020 and P025). Comments will not appear on PO. PW 7/7/26; CB 7/14/26
APPROVALS	Department Head signature approval for procurements under \$15,000. Procurement Officer Approval for ETSB.

COUNTY OF DUPAGE
501 – DuPage County Sheriff's Office
2026 Roofing Improvements



501 N County Farm Rd
Wheaton, IL 60187

OMNIA CERTIFIED PROPOSAL NUMBER: IL-R230404-309182

SERVICE REQUEST NUMBER: TRBM-309182

May 2026



Date: October 2024

RE: CUSTOMER PROPOSAL NUMBER IL-R230404-309182

Dear Valued OMNIA Member:

Thank you for your considering utilizing the OMNIA Cooperative Contractor Network method of delivery. Each contract in the OMNIA Partners portfolio has been competitively solicited and publicly awarded.

Tremco has implemented the Customer Proposal Number (CPN) system, a proposal registration program. This system will track transactions from the initial proposal stage to the completion of each project and provide consistency and faster service for your agency. It will also allow us to assist you with verification of contract compliance and consistency.

THE CPN PROCESS

Tremco will register your project and generate a CPN. That CPN (noted above) should be prominently displayed on all proposal related documents including Purchase Orders and invoices utilizing the OMNIA cooperative contract. The CPN will also alert our dedicated and experienced Tremco Cooperative Team, who will work to support you during the process.

Your Tremco representative may be found at <https://www.tremcoroofing.com/find-a-rep/>

Thank you for your participation with OMNIA.

Sincerely,

The Tremco Cooperative Team

SECTION 00 41 13 – QUOTATION FORM

Emailed Bids To: Geoff Matteson
geoffrey.matteson@dupagecounty.gov

Bid Due Date: **May 12, 2026 at 2:00PM**
 Malcor Roofing of IL, Inc

Bidder Name: _____
 Jason Doran

Contact: _____
 1850 dean street

Address: _____
 St Charles, IL

Telephone: _____
 630-849-4963

Re: Proposal for 2026 Roofing Improvements – 501 N County Farm Rd – Sheriff's Office
 Omnia National IPA Customer Proposal No. IL-R230404-309182

Dear Mr. Matteson,

Having carefully examined the instructions for quotations, project specifications, drawings, supporting documents and addenda issued prior to this date, we propose to furnish all labor, materials, equipment, transportation and other services required to successfully accomplish the work in accordance with the project documents.

This proposal and any work performed related to this proposal will be provided in accordance with the project documents and the terms, conditions and criteria established by Omnia/National IPA Contract No. R230404 - Roofing Products and Services. The Proposer will be solely responsible for delivering the project in accordance with Omnia National IPA Contract No. R230404 and the project documents.

- A. Base Quotation – Roofing Restoration at 501 N County Farm Rd, Wheaton IL – Roofs 12, 23, 25, 26 and 27 including wet replacement as identified in moisture survey and installation of 300 linear feet of anti-skid walkway:

\$ 487,000.00 .00

- B. Alternate Quotation 1 – Installation of exterior stair tower for exterior access to roofs.

\$ \$ 11,895.00 .00

- C. Unit Costs:

a. Additional wet polyisocyanurate replacement	\$ <u>2.50</u> /sqft
b. Replacement of drain head, plumbing connection and collar	\$ <u>3400.00</u> /drain
c. Replacement of cracked/broken drain clamping ring and strainer	\$ <u>675.00</u> /drain
d. Installation of additional fluid-applied anti-skid walkway	\$ <u>42.00</u> /lin. ft
e. Concrete deck repair	\$ <u>48.00</u> /sqft

- D. Addendum: The Proposer has received addendum numbers and incorporated provisions of such addendums in this quotation. Addendum(s) No(s) _____ thru _____ have been received and duly noted.
- E. The Proposer acknowledges scheduling for the construction of the specified project, which includes pre-construction activities, construction per major discipline, completion, project close out and commissioning.
 - a. Number of work days necessary 10 days.
- F. Accompanying this quotation is a certified or cashier's check or proposal bond payable to the order of DuPage County for not less than five (5%) percent of the greatest amount for which a contract can be awarded under this Proposal.
- G. A Performance Bond in the amount of 100% of the contract price shall be required from the successful bidder prior to execution of the contract.

The owner and their representatives reserve the right to waive any irregularities, to reject any or all Proposals, or to accept any Proposal.

Executed on May 11th, 2026
 Contractor Malcor Roofing of IL, Inc Taxpayer I.D. No.: 46.1189399

By: Jason Doran (If Contractor is a Corporation, complete the following)
 (Sole Owner, or Partner, or President of Corporation)

ATTEST _____
 (Corporate Seal)

Whose address is:
1850 dean street
St Charles, IL

Telephone No.: 630-849-4963
 Fax No.: Jason@malcorroofing.com

Sworn to and subscribed before me this 11th day of May, 2026.
 Notary Public in and for the State of Illinois

Signature of Notary _____
 Expiration Date of Notary Public Commission: _____

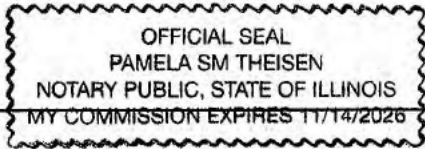

SECTION 070150.73 - REHABILITATION OF MODIFIED BITUMINOUS MEMBRANE ROOFING

PART 1 - GENERAL

1.1 SUMMARY

- A. This Section includes the following:
 - 1. Roof re-coating preparation.
 - 2. Application of fluid-applied roof membrane and flashings over existing granule-surfaced modified bituminous membrane roofing.

1.2 MATERIALS OWNERSHIP

- A. Demolished materials shall become Contractor's property and shall be removed from Project site.

1.3 DEFINITIONS

- A. Roofing Terminology: Refer to ASTM D1079 "Standard Terminology Relating to Roofing and Waterproofing" and glossary in NRCA's "The NRCA Roofing Manual: Membrane Roof Systems" for definition of terms related to roofing work in this Section.
- B. Roofing Coating Preparation: Existing roofing that is to remain and be prepared to accept restorative coating application.
- C. Patching: Removal of a portion of existing membrane roofing system from deck or removal of selected components and accessories from existing membrane roofing system and replacement with compatible similar materials.
- D. Remove: Detach items from existing construction and legally dispose of them off-site unless indicated to be removed and reinstalled.
- E. Existing to Remain: Existing items of construction that are not indicated to be removed.
- F. Construction Waste: Building and site improvement materials and other solid waste resulting from construction, remodeling, renovation, or repair operations. Construction waste includes packaging.
- G. Demolition Waste: Building and site improvement materials resulting from re-roofing preparation, demolition, or selective demolition operations.
- H. Disposal: Removal off-site of demolition and construction waste and subsequent sale, recycling, reuse, or deposit in landfill or incinerator acceptable to authorities having jurisdiction.

1.4 PREINSTALLATION MEETINGS

- A. Roofing Rehabilitation Preinstallation Conference: Conduct conference at Project site to review methods and procedures related to roofing system.
 - 1. Meet with Owner; roofing re-coating materials manufacturer's representative; roofing re-coating Installer including project manager and foreman; and installers whose work

interfaces with or affects re-coating including installers of roof accessories and roof-mounted equipment requiring removal and replacement as part of the Work.

2. Review methods and procedures related to re-coating preparation, including membrane roofing system manufacturer's written instructions.
3. Review drawings and specifications.
4. Procedures for salvaging and recycling of demolition and construction waste
5. Review temporary protection requirements for existing roofing system that is to remain, during and after installation.
6. Review roof drainage during each stage of re-coating and review plugging and plug removal procedures.
7. Review and finalize construction schedule, and verify availability of materials, Installer's personnel, equipment, and facilities needed to make progress and avoid delays.
8. Review methods and procedures related to re-coating preparation, including coating manufacturer's written instructions.
9. Review base flashings, special roofing details, drainage, penetrations, equipment curbs, and condition of other construction that will affect re-coating.
10. Review HVAC shutdown and sealing of air intakes.
11. Review shutdown of fire-suppression, -protection, and -alarm and -detection systems.
12. Review procedures for asbestos removal or unexpected discovery of asbestos-containing materials.
13. Review governing regulations and requirements for insurance and certificates if applicable.
14. Review existing conditions that may require notification of Owner before proceeding.

1.5 ACTION SUBMITTALS

- A. Product Data: For each type of product specified.

1.6 INFORMATIONAL SUBMITTALS

- A. Existing Conditions Photographs: Show existing conditions of adjoining construction and site improvements, including exterior and interior finish surfaces, which might be misconstrued as having been damaged by re-coating operations. Submit before Work begins.
- B. Proposed Protection Measures: Submit report, including Drawings, that indicates the measures proposed for protecting individuals and property, for environmental protection, and for dust control. Indicate proposed locations and construction of barriers.
- C. Field Quality Control Reports: Reports of Roofing Inspector. Include weather conditions, description of work performed, tests performed, defective work observed, and corrective actions required and carried out.

- D. Manufacturer's Instructions: Submit copy of manufacturer's written installation instructions for specified roofing system.

1.7 CLOSEOUT SUBMITTALS

- A. Maintenance Data: To include in maintenance manuals.
- B. Warranties: Executed copies of approved warranty forms.

1.8 QUALITY ASSURANCE

- A. Installer Qualifications: An employer of workers trained and certified by manufacturer, including a full-time on-site supervisor with a minimum of five years' experience installing products comparable to those specified, able to communicate verbally with Contractor, and employees, and qualified by the manufacturer to install manufacturer's product and furnish warranty of type specified.
- B. Manufacturer Qualifications: Primary product manufacturer with minimum five years' experience in manufacture of comparable products in successful use in similar applications, and able to furnish warranty with provisions matching specified requirements.
- C. Roofing Inspector Qualifications: A technical representative of manufacturer not engaged in the sale of products and experienced in the installation and maintenance of the specified roofing system, qualified to perform roofing observation and inspection specified in Field Quality Control Article, to determine Installer's compliance with the requirements of this Project, and approved by the manufacturer to issue warranty certification. The Roofing Inspector shall be one of the following:
 - 1. An authorized full-time technical employee of the manufacturer.
 - 2. An independent party certified as a Registered Roof Observer by the International Institute of Building Enclosure Consultants (formerly the Roof Consultants Institute) retained by the Contractor or the Manufacturer and approved by the Manufacturer.
- D. Manufacturer's Installation Instructions: Obtain and maintain on-site access to manufacturer's written recommendations and instructions for installation of products.

1.9 PROJECT / FIELD CONDITIONS

- A. Weather Limitations: Proceed with rehabilitation work only when existing and forecasted weather conditions permit Work to proceed without water entering into existing roofing system or building.
 - 1. Store all materials prior to application at temperatures recommended by manufacturer.
 - 2. Apply coatings within range of ambient and substrate temperatures recommended by manufacturer.
 - 3. Do not apply roofing in snow, rain, fog, or mist.
- B. Discard and legally dispose of liquid material that cannot be applied within its stated shelf life or application time frame.

- C. Protect building to be rehabilitated, adjacent buildings, walkways, site improvements, exterior plantings, and landscaping from damage or soiling from rehabilitation operations.
 - 1. Handle and store roofing materials and place equipment in a manner to avoid permanent deflection of deck.
- D. Maintain access to existing walkways, corridors, and other adjacent occupied or used facilities.
- E. Daily Protection: Coordinate installation of roofing so insulation and other components of roofing system, that are not to be permanently exposed, are not subjected to precipitation or left uncovered at the end of the workday or when rain is forecast.
- F. Owner will occupy portions of building immediately below re-coating area. Conduct re-coating so Owner's operations will not be disrupted. Provide Owner with not less than 72 hours' notice of activities that may affect Owner's operations.

1.10 WARRANTY

- A. Manufacturer's Warranty: Roof System Manufacturer's standard form in which Manufacturer agrees to repair or replace components of roofing system that fail in materials or workmanship within warranty period, as follows.
 - 1. Form of Warranty: Manufacturer's standard warranty form.
 - 2. Scope of Warranty: Work of this Section and including sheet metal details and termination details installed by the roof system Installer and approved by the Roof System Manufacturer.
 - 3. Warranty Period: 20 years from date of completion.
- B. Manufacturer Inspection Services: By manufacturer's technical representative, to report maintenance responsibilities to Owner necessary for preservation of Owner's warranty rights. The cost of manufacturer's inspections is included in the Contract Sum.
 - 1. Inspections to occur in following years: 2, 5, 10 and 15 following completion.
- C. Installer Warranty: Installer's warranty signed by Installer, as follows.
 - 1. Form of Warranty: Form included in Project Manual.
 - 2. Scope of Warranty: Work of this Section.
 - 3. Warranty Period: 2 years from date of completion.

PART 2 - PRODUCTS

2.1 MANUFACTURERS

- A. Basis of Design: The restoration system specified in this Section is based upon products of Tremco CPG Inc, Beachwood, OH, (800) 562-2728, www.tremcoroofing.com that are named in other Part 2 articles. Provide specified products or comparable products of one of the following.
 - 1. Manufacturers of comparable products: Approved by Owner prior to bid.

- B. Source Limitations: Obtain components for roofing system from same manufacturer as membrane roofing or manufacturer approved by membrane roofing manufacturer.

2.2 PERFORMANCE REQUIREMENTS

- A. General Performance: Rehabilitated roofing shall withstand exposure to weather without failure or leaks due to defective manufacture or installation.
 - 1. Accelerated Weathering: Roofing system shall withstand 5000 hours of exposure when tested according to ASTM G152, ASTM G154, or ASTM G155.
- B. Material Compatibility: Provide roofing materials that are compatible with one another under conditions of service and application required, as demonstrated by roofing manufacturer based on testing and field experience.
- C. Exterior Fire-Test Exposure: Roofing system exterior fire-test exposure performance following application of rehabilitation coating shall be not be less than that of the pre-rehabilitated roof performance when tested in accordance with ASTM E108 or UL 790, based upon manufacturer's tests of identical applications.
- D. Bio-Based Content: Provide roofing rehabilitation coating materials meeting requirements of USDA Bio-based Affirmative Procurement Program, with not less than 20 percent bio-based content.

2.3 MATERIALS

- A. General: Re-coating materials recommended by roofing system manufacturer for intended use and compatible with components of existing membrane roofing system.
- B. Infill Materials: Where required to replace test cores and to patch existing roofing, use infill materials matching existing membrane roofing system materials, unless otherwise indicated.
- C. Temporary Roof Drainage: Design and selection of materials for temporary roof drainage are responsibilities of the Contractor.

2.4 FLUID-APPLIED ROOFING MEMBRANE COATING

- A. Polyurethane Elastomeric Fluid-Applied System: Two-coat fluid-applied roofing membrane formulated for application over prepared existing roofing substrate.
 - 1. Polyurethane Roof Coating System Base Coat: Bio-based, low-odor low-VOC two-part, for use with a compatible top coat.
 - a. Basis of design product: Tremco, AlphaGuard BIO Base Coat.
 - b. Combustion Characteristics, UL 790: Maintains combustion characteristics of existing roof system.
 - c. Volatile Organic Compounds (VOC), maximum, ASTM D3960: 1 g/L.
 - d. Accelerated Weathering, 5000 hours, ASTM G154: Pass.
 - e. Hardness, Shore A, minimum, ASTM D2240: 80.

- f. Solids, by volume, ASTM D2697: 100 percent.
 - g. Bio-Based Content, Minimum: 70 percent.
 - h. Minimum Thickness, Base Coat reinforced over Granular Surfaced MB: 64 mils (1.62 mm) wet.
2. Polyurethane roof coating system top coat, bio-based low-odor low-VOC two-part, for application over compatible base coat.
- a. Basis of design product: Tremco, AlphaGuard BIO Top Coat.
 - b. Combustion Characteristics, UL790: Maintains combustion characteristics of existing roof system.
 - c. Volatile Organic Compounds (VOC), maximum, ASTM D3960: 6 g/L.
 - d. Solar Reflectance Index (SRI), ASTM E1980: For white, not less than 103.
 - e. Accelerated Weathering, 5000 hours, ASTM G 154: Pass.
 - f. Hardness, Shore A, minimum, ASTM D2240: 81.
 - g. Solids, by volume, ASTM D2697: 100 percent.
 - h. Bio-Based Content, Minimum: 60 percent.
 - i. Minimum Thickness, reinforced system: 32 mils (0.81 mm) wet.
 - j. Minimum Thickness, Slip-Resistant Coat: 24 mils (0.60 mm) wet.
 - k. Color: White.

B. Primers:

- 1. Primer for Non-Porous Surfaces: Single-part, water based primer to promote adhesion of urethanes to metals, PVC and other non-porous surfaces.
 - a. Basis of design product: Tremco, AlphaGuard M-Prime.
 - b. Volatile Organic Compounds (VOC), maximum, ASTM D3960: 22 g/L.
 - c. Nonvolatile Content, minimum, ASTM D2369: 5 percent.
 - d. Density at 77 deg F (25 deg C): 8.3 lb/gal (1kg/L).
- 2. Reactivation Primer: Single-component primer used to prepare aged bio-based urethane coating products, and for intercoat repriming of bio-based urethane coatings which have cured for more than 72 hours.
 - a. Basis of design product: Tremco, BIO Prime.
 - b. Coverage Rate: 1/4 gal / 100 sq. ft. (0.1 L/m²) (4 wet mils) minimum.

C. Fluid-Applied Membrane Reinforcing Fabric:

1. Polyester Reinforcing Fabric: 100 percent stitch-bonded mildew-resistant polyester fabric intended for reinforcement of compatible fluid-applied membranes and flashings.
 - a. Basis of design product: Tremco, Permafab.
 - b. Tensile Strength, Minimum, ASTM D5034 (2-inch): MD - 110 lbs (49.8 kg); XMD - 60 lbs (27.2 kg) avg.
 - c. Elongation, Minimum, ASTM D5034 (1-inch): MD - 25 percent; XMD - 100 percent.
 - d. Tear Strength, Minimum, ASTM D5587: MD - 20 lbs (9.0 kg) avg; XMD - 20 lbs (9.0 kg) avg.
 - e. Weight: 3 oz./sq. yd (102 g/sq. m).

2.5 AUXILIARY MATERIALS

A. General: Auxiliary materials recommended by roofing system manufacturer for intended use and compatible with existing roofing system and fluid-applied roofing system.

B. Seam Sealer: Waterproof seam and patching material compatible with applied coating.

1. Seam Sealer: Aromatic polyurethane sealer, single-component, high solids, moisture curing, formulated for compatibility and use with a variety of roofing and flashing substrates.
 - a. Basis of design product: Tremco, GEOGARD Seam Sealer.
 - b. Volatile Organic Compounds (VOC), maximum, ASTM D3960: 189 g/L.
 - c. Tensile Strength, ASTM D412: 270 psi (1860 kPa).
 - d. Tear Strength, ASTM D412: 35 pli (6.13 kNm).
 - e. Elongation, ASTM D412: 220 percent.
 - f. Color: Gray.

C. Seam and Detail Reinforcing Fabric:

1. Polyester Reinforcing Fabric: 100 percent stitch-bonded mildew-resistant polyester fabric intended for reinforcement of compatible fluid-applied membranes and flashings.
 - a. Basis of design product: Tremco, Permafab.
 - b. Tensile Strength, Minimum, ASTM D5034 (2-inch): MD - 110 lbs (49.8 kg); XMD - 60 lbs (27.2 kg) avg.
 - c. Elongation, Minimum, ASTM D5034 (1-inch): MD - 25 percent; XMD - 100 percent.
 - d. Tear Strength, Minimum, ASTM D5587: MD - 20 lbs (9.0 kg) avg; XMD - 20 lbs (9.0 kg) avg.

- e. Weight: 3 oz./sq. yd (102 g/sq. m).
- D. Joint Sealant: Elastomeric joint sealant compatible with applied coating, with movement capability appropriate for application.
 - 1. [Click here to select joint sealant.](#)
- E. Fasteners: Factory-coated steel fasteners and metal or plastic plates meeting corrosion-resistance provisions in FM 4470; designed for fastening roofing membrane components to substrate; tested by manufacturer for required pullout strength; and acceptable to roofing system manufacturer.
- F. Metal Flashing Sheet: Provide metal flashing sheet matching type, thickness, finish, and profile of existing metal flashing and trim.
 - 1. Slip Flashing: Fabricate from the following material:
 - a. Galvanized Steel or Aluminum-Zinc Alloy-Coated Steel, ASTM A653/A653M, G90 (Z275) or ASTM A792/A792M, Class AZ50 (Class AZM150): 0.028 inch/24 ga. (0.71 mm) thick.
- G. Miscellaneous Accessories: Provide miscellaneous accessories recommended by roofing system manufacturer.

2.6 WALKWAYS

- A. Walkway Materials:
 - 1. Polyurethane Top Coat, Slip-Resistant: Second top coat with broadcast slip-resistant aggregate.
 - a. Basis of design product: Tremco, AlphaGuard Top Coat Slip-Resistant.
 - b. Minimum Thickness: As indicated in Part 2 product listing; over cured top coat.
 - c. .
 - d. Ceramic granules: 10 to 15 lb/100 sq. ft.
 - e. Color: As selected from manufacturer's standard colors.
 - 2. Granular Roofing Surfacing: Ceramic-coated roofing granules, No. 11 screen size with 100 percent passing No. 8 (2.36-mm) sieve and 98 percent of mass retained on No. 40 (0.425-mm) sieve.
 - a. Basis of design product: Granular Roofing Surfacing, Colored.
 - b. Aggregate application rate, average: 10 - 15 lb/100 sq ft (0.5 - 0.75 k/m²).
 - c. Color: Match cap sheet granules.
 - 3. Color: White.
 - a. Include 4-inch- (100-mm-) wide outline stripes; YELLOW.

PART 3 - EXECUTION

3.1 EXAMINATION

- A. Examine existing roofing substrates, with Installer present, for compliance with requirements and for other conditions affecting application and performance of roof coatings.
 - 1. For the record, prepare written report, endorsed by Installer, listing conditions detrimental to performance.
 - 2. Verify compatibility of approved re-coating system with and suitability of substrates.
 - 3. Verify that substrates are visibly dry and free of moisture.
 - 4. Verify that roofing membrane surfaces have adequately aged to enable proper bond with re-coating system base coat.
 - 5. Verify that existing roofing membrane is free of blisters, splits, open laps, indications of shrinkage, and puncture damage or other indications of impending roof system failure.
 - 6. Commencing application of fluid-applied re-coating membrane indicates acceptance of surfaces and conditions.

3.2 PREPARATION

- A. Protect existing roofing system that is indicated not to be rehabilitated, and adjacent portions of building and building equipment.
 - 1. Mask surfaces to be protected. Seal joints subject to infiltration by coating materials.
 - 2. Limit traffic and material storage to areas of existing roofing membrane that have been protected.
 - 3. Maintain temporary protection and leave in place until replacement roofing has been completed.
- B. Pollution Control: Comply with environmental regulations of authorities having jurisdiction. Limit spread of dust and debris.
 - 1. Remove and transport debris in a manner that will prevent spillage on adjacent surfaces and areas.
 - 2. Remove debris from building roof by chute, hoist, or other device that will convey debris to grade.
- C. Verify that rooftop utilities and service piping affected by the Work have been shut off before commencing Work.
- D. Shut down air intake equipment in the vicinity of the Work in coordination with the Owner. Cover air intake louvers before proceeding with re-coating work that could affect indoor air quality or activate smoke detectors in the ductwork.
- E. Maintain roof drainage components in functioning condition to ensure roof drainage at end of each workday. Prevent debris from entering or blocking roof drainage and conductors. Use

plugs specifically designed for this purpose. Remove plugs at end of each workday, when no work is taking place, or when rain is forecast.

1. Do not permit water to enter into or under existing membrane roofing system components that are to remain.

3.3 ROOFING COATING PREPARATION

- A. Removal of Wet Insulation: Remove portions of roofing membrane with underlying wet insulation. Remove wet insulation, fill in tear-off areas to match existing insulation and membrane, and prepare patched membrane for roof coating application specified below.
- B. Repair of Ponding Areas: Repair areas indicated as ponding areas or areas of inadequate drainage by removing roof membrane, adding additional insulation as required to provide minimum slopes to drain required by roofing rehabilitation coating manufacturer, and replace membrane with material matching existing. Submit photographic report indicating compliance.
- C. Membrane Surface Preparation:
 1. Remove loose granular aggregate from granular-surfaced modified bituminous roofing with a power broom.
 2. Remove pavers and walkway pads from roofing membrane.
 3. Remove blisters, ridges, buckles, roofing membrane fastener buttons projecting above the membrane, and other substrate irregularities from existing roofing membrane that would inhibit application of uniform, waterproof coating.
 4. Broom clean existing substrate.
 5. Substrate Cleaning: Clean substrate in accordance with requirements of Division 07 Section "Maintenance Cleaning of Membrane Roofing."
 6. Substrate Cleaning: Clean substrate of contaminants such as dirt, debris, oil, and grease that can affect adhesion of coating by power washing at minimum 2,000 psi. (13,800 kPa).
 - a. Dispose of waste water in accordance with requirements of authorities having jurisdiction.
 7. Verify that existing substrate is dry before proceeding with application of coating. Spot check substrates with an electrical capacitance moisture-detection meter.
 8. Verify adhesion of new products.
- D. Existing Flashing and Detail Preparation: Repair flashings, gravel stops, copings, and other roof-related sheet metal and trim elements. Reseal joints, replace loose or missing fasteners, and replace components where required to leave in a watertight condition.
 1. Do not damage metal counterflashings that are to remain. Replace metal counterflashings damaged during removal with counterflashings of same metal, weight or thickness, and finish.

2. Roof Drains: Remove drain strainer and clamping ring. Grind metal surfaces down to clean, bare, metal.
- E. Surface Priming: Prime surfaces to receive fluid-applied coating using coating manufacturer's recommended product for surface material. Apply at application rate recommended by manufacturer.
1. Ensure primer does not puddle and substrate has complete coverage.
 2. Allow to cure completely prior to application of coating.
- F. Membrane Repair: Repair membrane at locations with irregularities using seam sealer mastic and reinforcing fabric.
- G. Membrane Seam Reinforcement: Reinforce membrane seams using seam sealer mastic and reinforcing fabric overlapping onto field of existing membrane not less than width required by roof coating manufacturer.

3.4 FLUID-APPLIED FLASHING APPLICATION

- A. Fluid-Applied Flashing and Detail Base Coat Application: Complete base coat and fabric reinforcement at parapets, curbs, penetrations, and drains prior to application of field of fluid-applied membrane. Apply base coat in accordance with manufacturer's written instructions.
1. Apply base coat on prepared and primed surfaces and spread coating evenly. Extend coating minimum of 8 inches (200 mm) up vertical surfaces and 4 inches (100 mm) onto horizontal surfaces.
 2. Back roll to achieve not less than minimum coating thickness indicated in Part 2 product listing, unless greater thickness is recommended by manufacturer. Verify thickness as work progresses.
 3. Fabric Reinforcement: Embed fabric reinforcement into wet base coat. Lap adjacent flashing pieces of fabric minimum 3 inches (75 mm) along edges and 6 inches (150 mm) at end laps.
 - a. Roll surface of fabric reinforcing to completely embed and saturate fabric. Leave finished base coat with fabric free of pin holes, voids, or openings.
 4. Roof Drains: Install base coat onto surrounding membrane surface and metal drain bowl flange. Install target piece of fabric reinforcement immediately into wet base coat and roll to fully embed and saturate fabric. Reinstall clamping ring and strainer following application of top coat. Replace broken drain ring clamping bolts.
 5. Allow base coat to cure prior to application of top coat.
 6. Following curing of base coat and prior to application of top coat, sand raised or exposed edges of fabric reinforcement.

3.5 FLUID-APPLIED MEMBRANE APPLICATION

- A. Fluid-Applied Membrane Base Coat: Apply base coat to field of membrane in accordance with manufacturer's written instructions.

1. Apply base coat on prepared and primed surfaces and spread coating evenly.
 2. Back roll to achieve not less than minimum coating thickness indicated in Part 2 product listing, unless greater thickness is recommended by manufacturer. Verify thickness as work progresses.
 3. Fabric Reinforcement: Embed fabric reinforcement into wet base coat. Lap adjacent flashing pieces of fabric minimum 3 inches (75 mm) along edges and 6 inches (150 mm) at end laps.
 - a. Roll surface of fabric reinforcing to completely embed and saturate fabric. Leave finished base coat with fabric free of pin holes, voids, or openings.
 4. Allow base coat to cure prior to application of top coat.
 5. Following curing of base coat and prior to application of top coat, sand raised or exposed edges of fabric reinforcement.
- B. Top Coat Application: Apply top coat to field of membrane and flashings uniformly in a complete, continuous installation.
1. Prime base coat prior to application of top coat if top coat is not applied within 72 hours of the base coat application, using manufacturer's recommended primer.
 2. Apply top coat extending coating up vertical surfaces and out onto horizontal surfaces. Install top coat over field base coat and spread coating evenly.
 3. Back roll to achieve not less than minimum coating thickness indicated in Part 2 product listing, unless greater thickness is recommended by manufacturer. Verify thickness as work progresses.
 4. Avoid foot traffic on new fluid-applied membrane for a minimum of 24 hours.

3.6 WALKWAY INSTALLATION

- A. Walkways, General: Install walkways according to roofing manufacturer's written instructions.
1. Install walkways at following locations:
 - a. Where indicated on Drawings.
- B. Slip-Resistant Walkway Topcoat: Apply walkway second topcoat following application and curing of top coat. Locate as indicated.
1. Mask walkway location with tape.
 2. Prime first top coat prior to application of walkway top coat if walkway top coat is not applied within 72 hours of the first top coat application, using manufacturer's recommended primer.
 3. Apply walkway topcoat and back roll to achieve minimum coating thickness indicated on Part 2 product listing, unless greater thickness is recommended by manufacturer; verify thickness of base coat as work progresses.

4. Broadcast Slip-Resistant Top Coat Aggregate in wet top coat at rate indicated in Part 2 product listing or as otherwise recommended by coating manufacturer.
 - a. Back roll aggregate and top coat creating even dispersal of aggregate.
5. Remove masking immediately.

3.7 FIELD QUALITY CONTROL

- A. Roof Inspection: Engage roofing system manufacturer's technical personnel to inspect roofing installation, and submit report. Notify Owner 48 hours in advance of dates and times of inspections. Inspect work as follows:
 1. Upon completion of preparation of roof coating substrate, prior to application of coating materials.
 2. Following application of coating to flashings and application of base coat to field of roof.
 3. Upon completion of coating but prior to re-installation of other roofing components.
- B. Repair fluid-applied membrane where test inspections indicate that they do not comply with specified requirements.
- C. Arrange for additional inspections, at Contractor's expense, to verify compliance of replaced or additional work with specified requirements.

3.8 DISPOSAL

- A. Collect demolished materials and place in containers. Promptly dispose of demolished materials. Do not allow demolished materials to accumulate on-site.
 1. Storage or sale of demolished items or materials on-site is not permitted.
- B. Transport and legally dispose of demolished materials off Owner's property.

3.9 PROTECTING AND CLEANING

- A. Protect roofing system from damage and wear during remainder of construction period.
- B. Correct deficiencies in or remove coating that does not comply with requirements, repair substrates, and reapply coating.
- C. Clean overspray and spillage from adjacent construction using cleaning agents and procedures recommended by manufacturer of affected construction.

END OF SECTION 070150.73

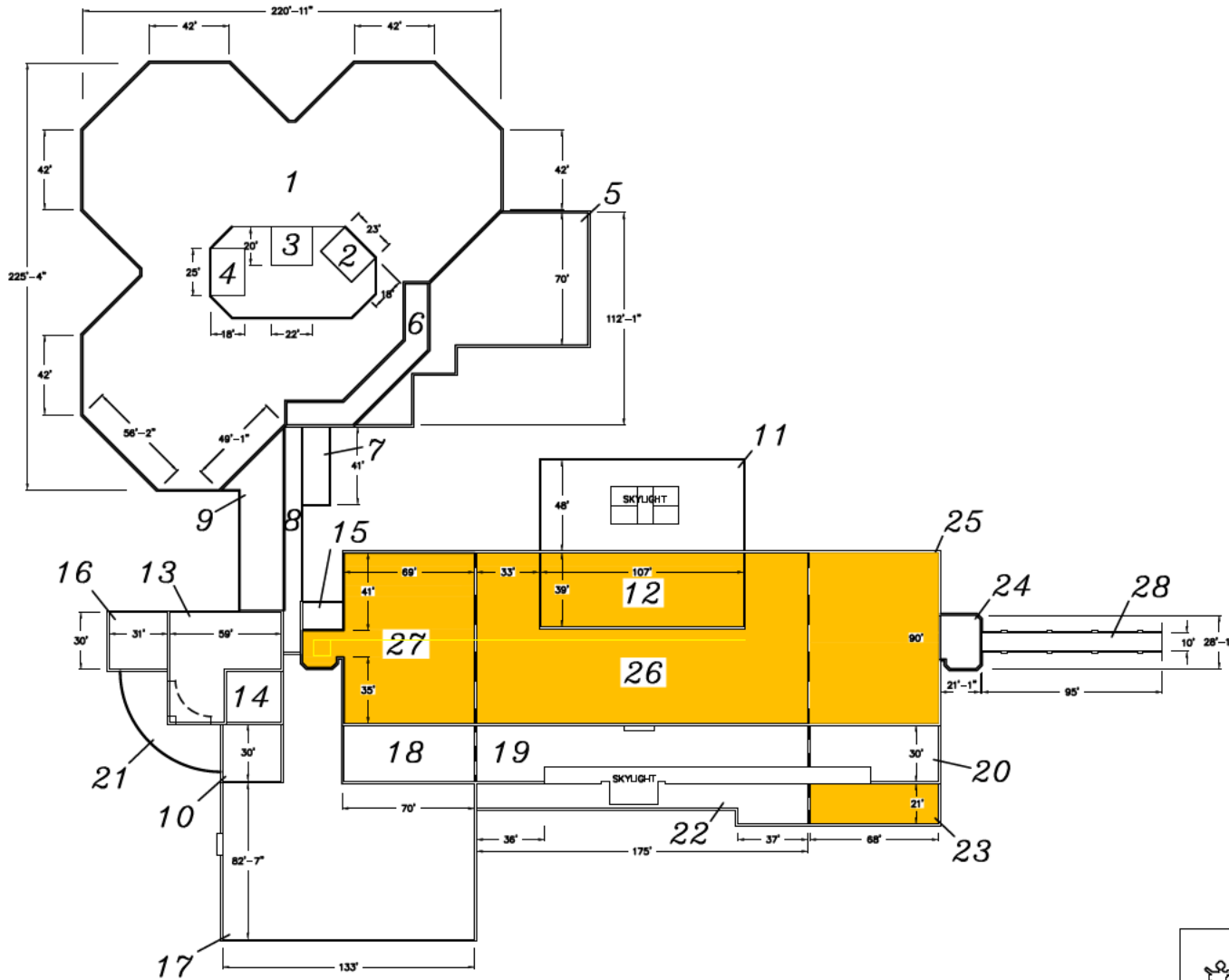

ROOF NAME	SQUARE FEET	ROOF NAME	SQUARE FEET
1	33,776	15	284
2	414	16	830
3	440	17	12,894
4	450	18	2,070
5	5,853	19	4,090
6	1,393	20	1,784
7	574	21	1,652
8	1,021	22	2,293
9	2,031	23	1,428
10	830	24	572
11	4,418	25	6,120
12	4,173	26	11,390
13	2,562	27	6,611
14	783	28	948
TOTAL SQUARE FEET		111,900	

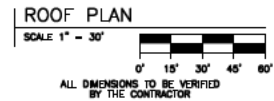
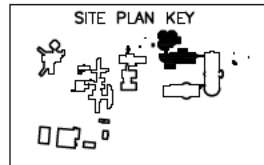

REVISIONS	No.	DATE	BY

NOTES:

- LEGEND:**
- * CORE
 - + DRAIN / OVERFLOW DRAIN
 - = SCUPPER / OVERFLOW SCUPPER
 - EXPANSION JOINT / CONTROL JOINT
 - - - HIDDEN LINE
 - RIDGE LINE



CUSTOMER: COUNTY OF DUPAGE
 BUILDING: GOVERNMENT CENTER
 COUNTY JUDICIAL COMPLEX
 SHERIFF'S OFFICE AND JAIL
 LOCATION: WHEATON, ILLINOIS
 DRAWN BY: WB DATE DRAWN: 11 / 5 / 10 FILE NAME: M18 \ JO_SHOU
 APPROVED: TS SURVEY DATE: 9 / 22 / 10 AGREEMENT #: 137455

Roof Project:

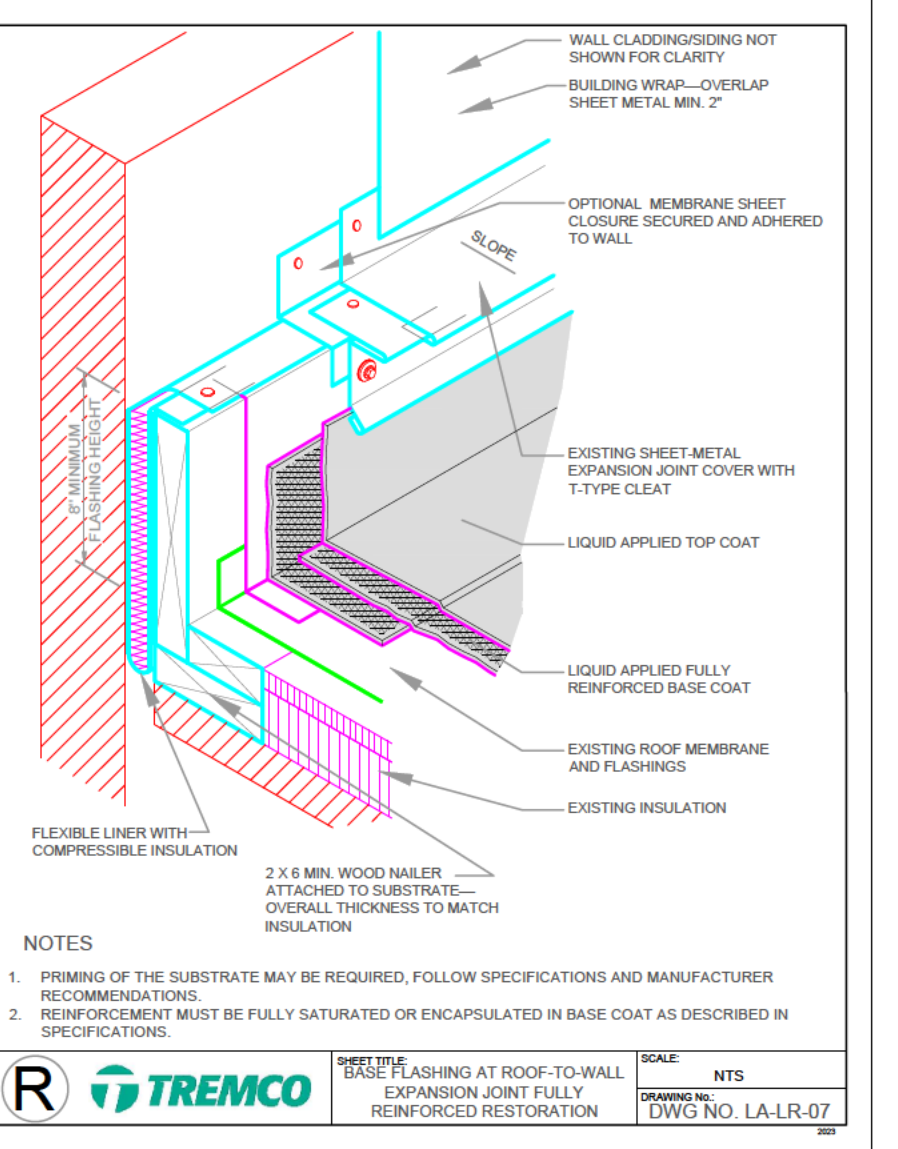
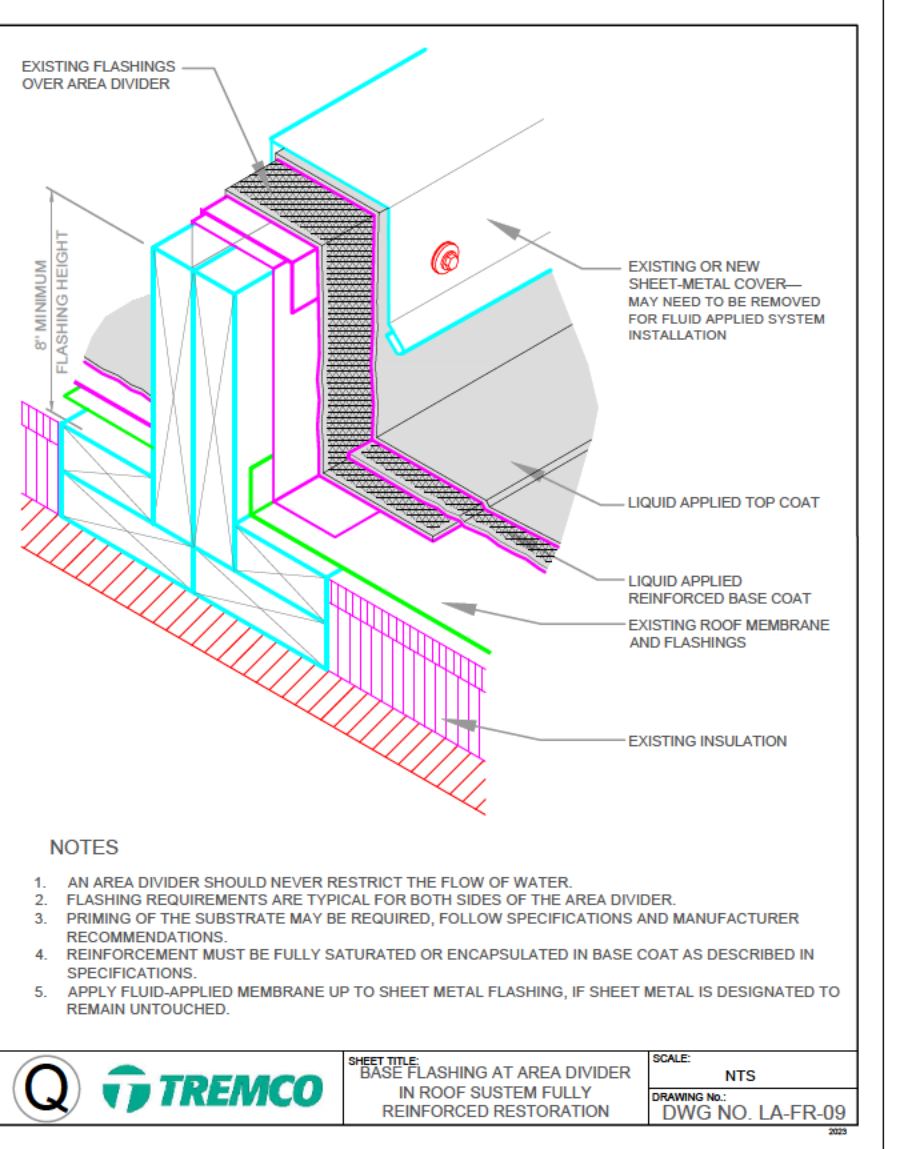
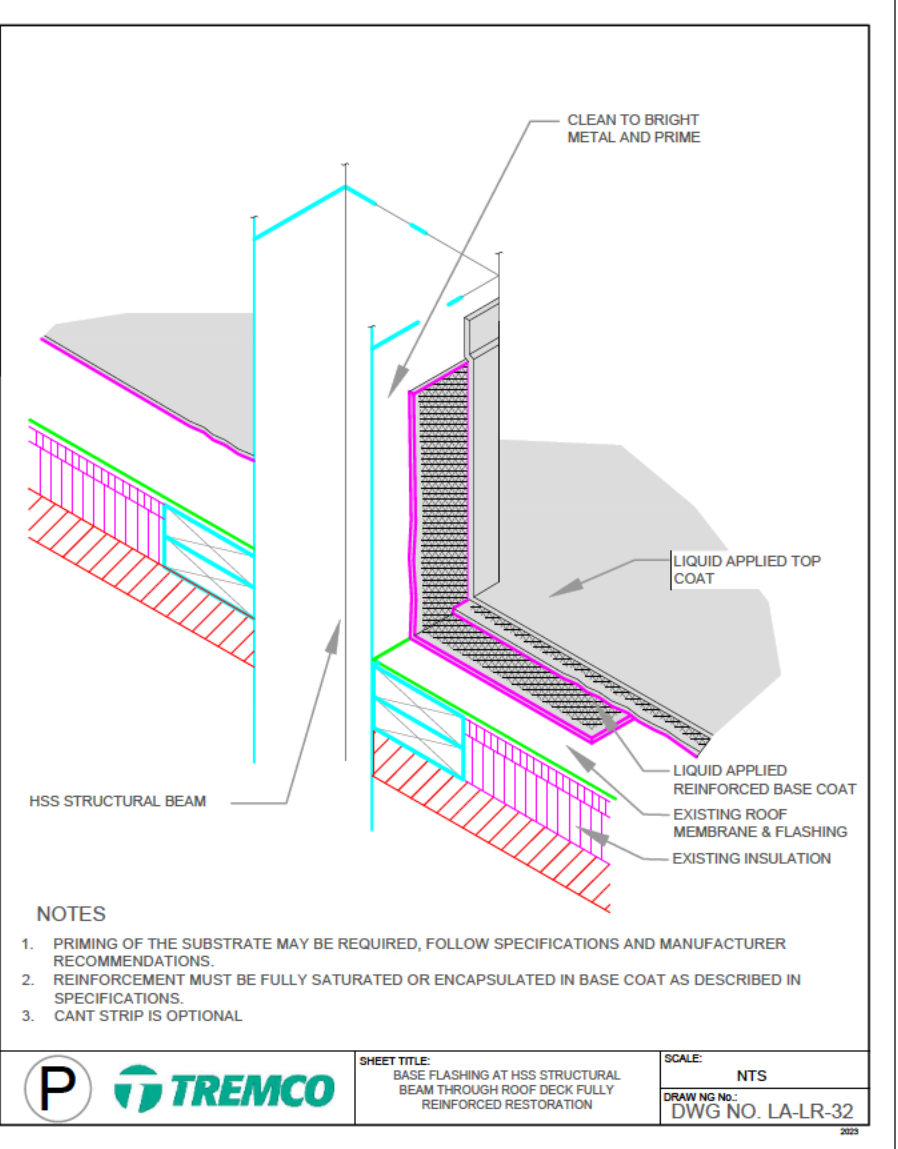
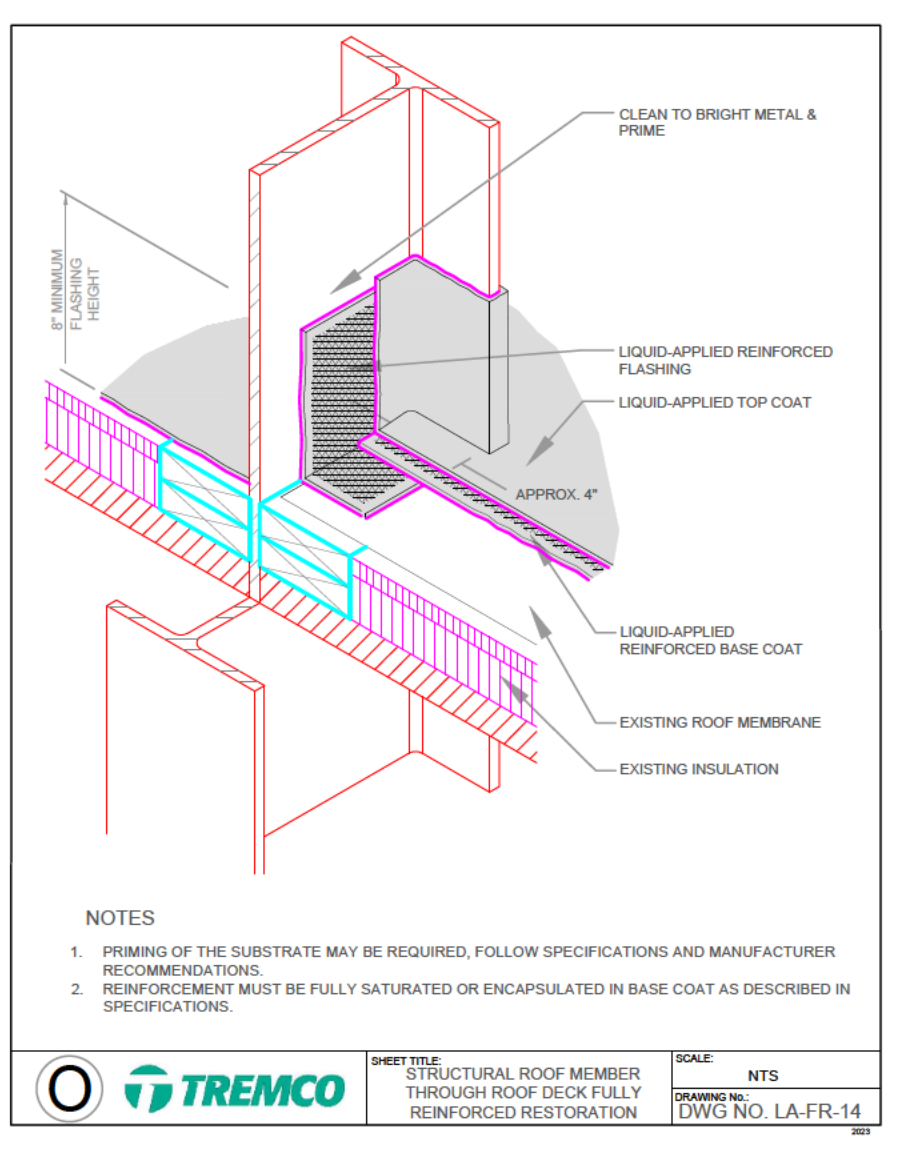
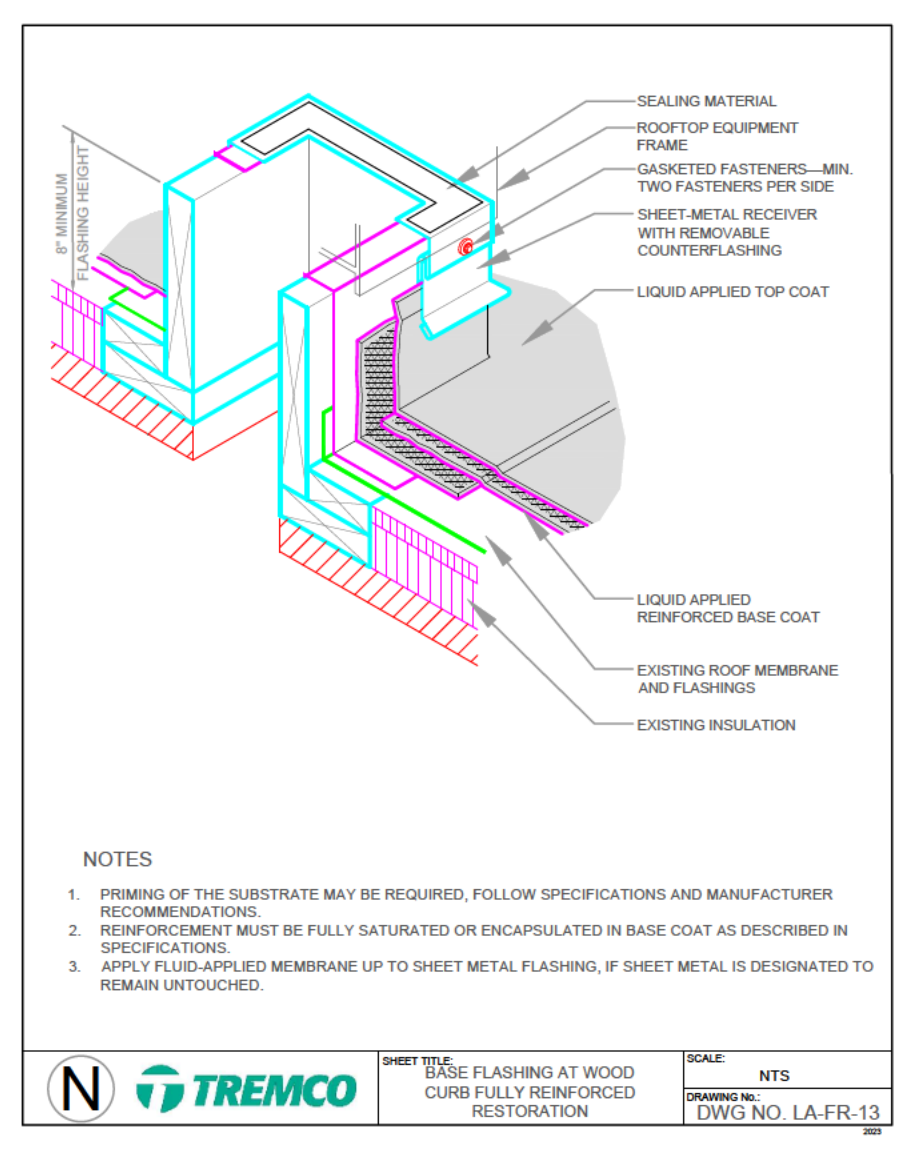
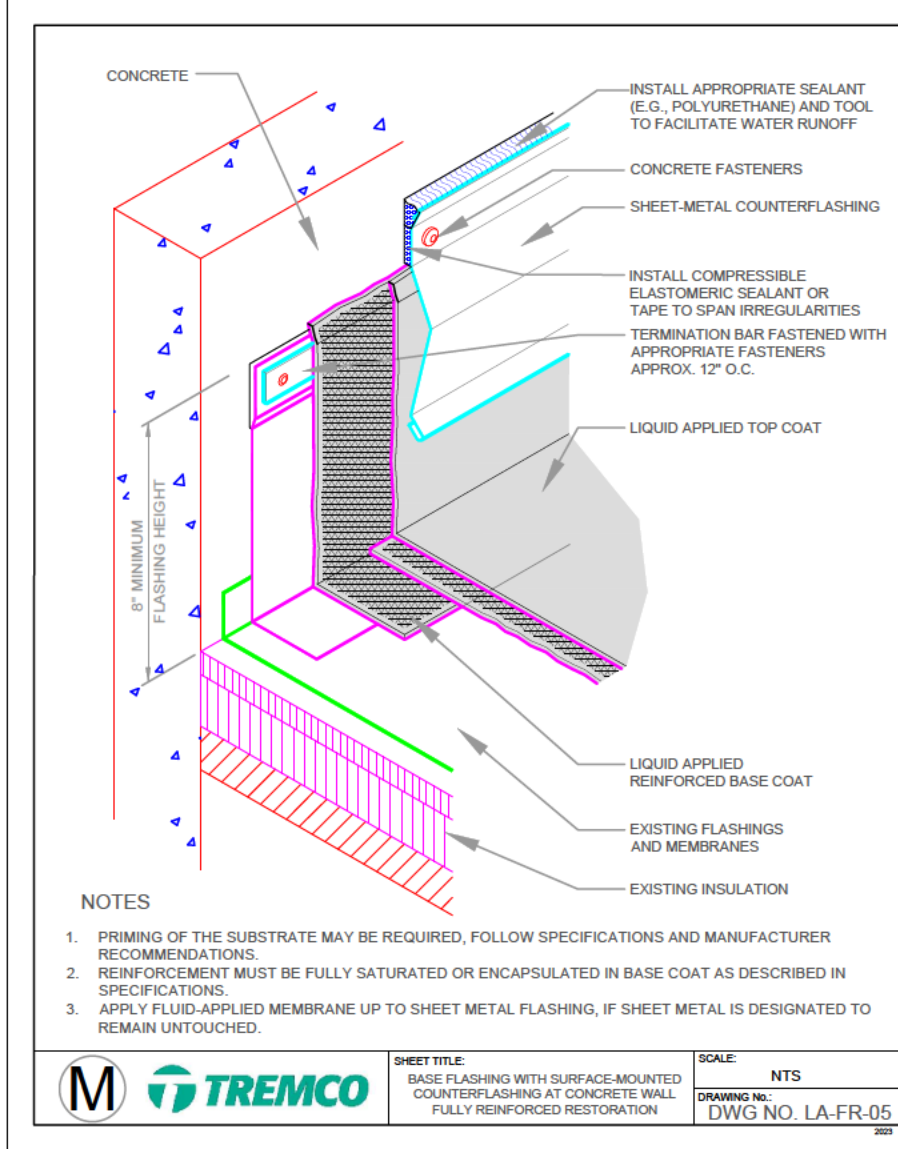
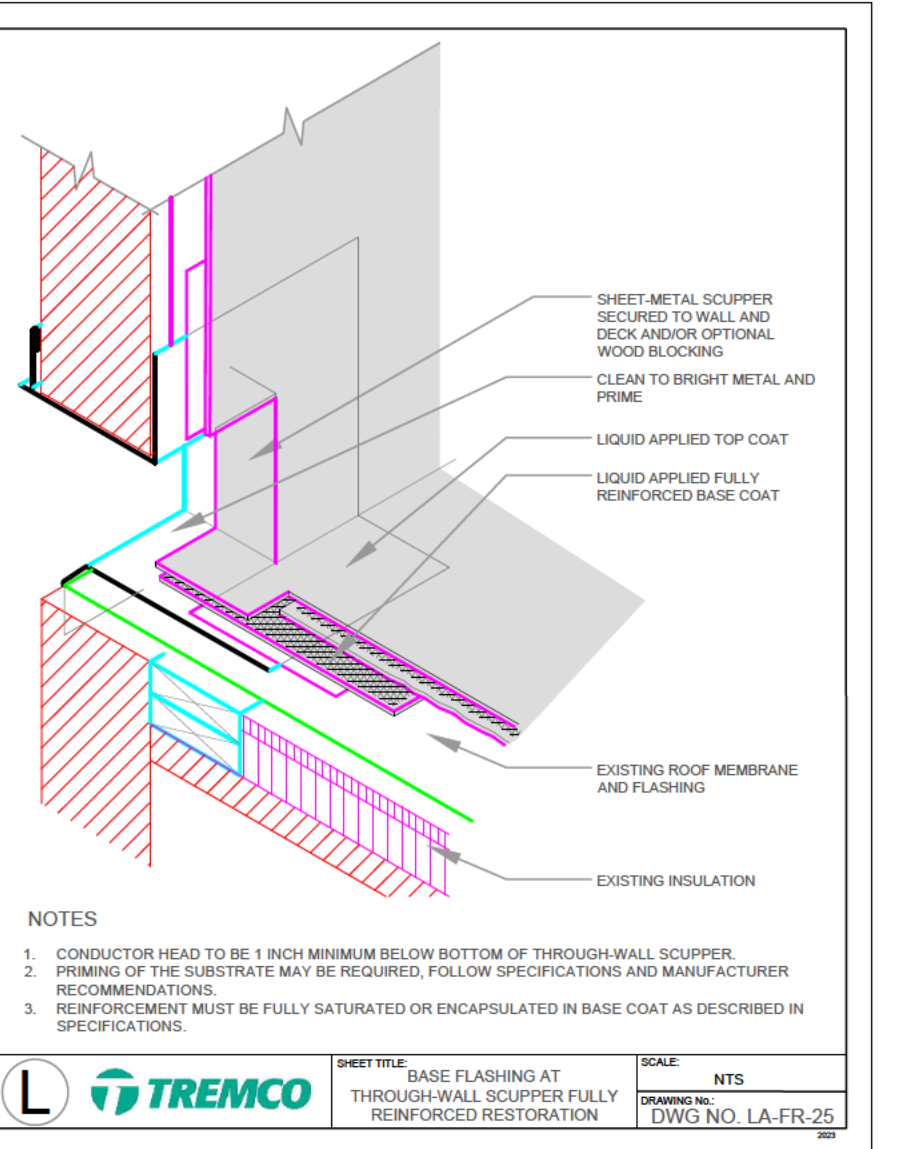
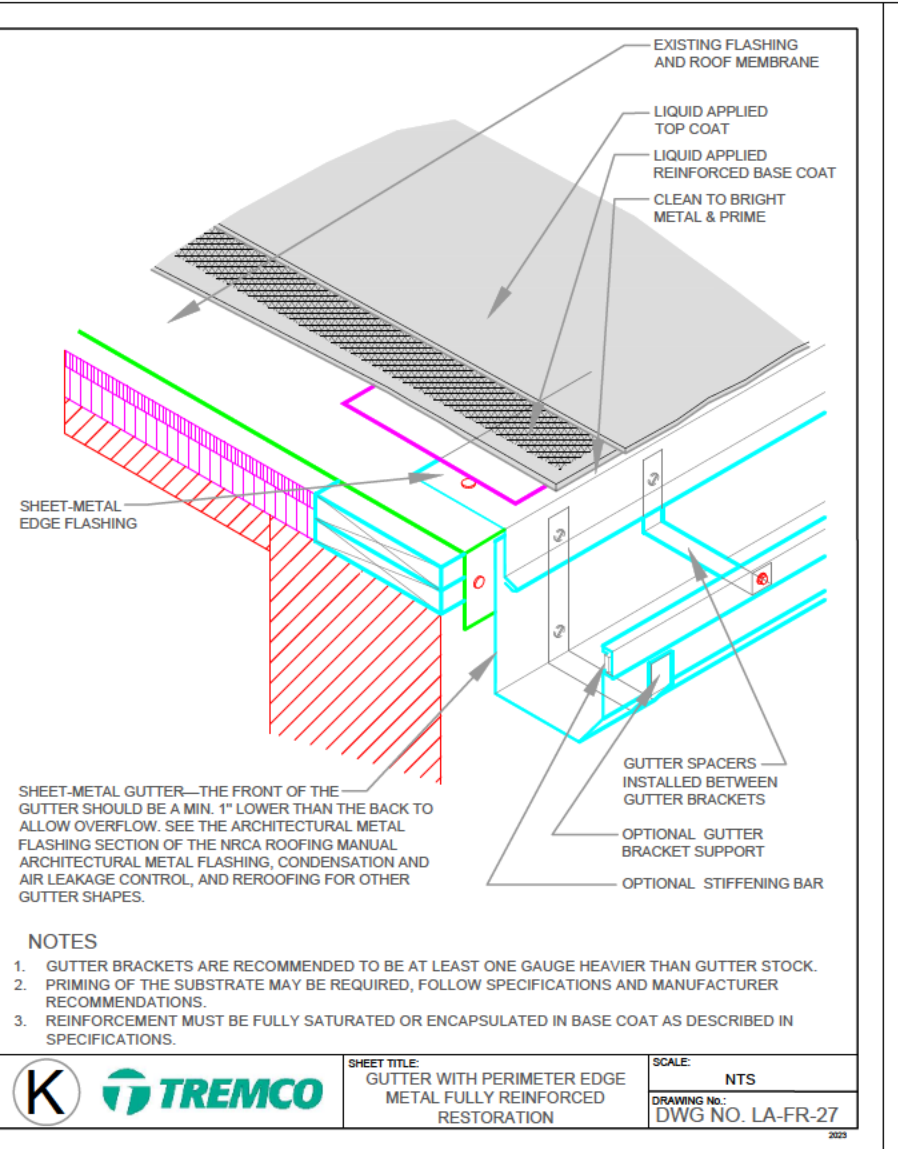
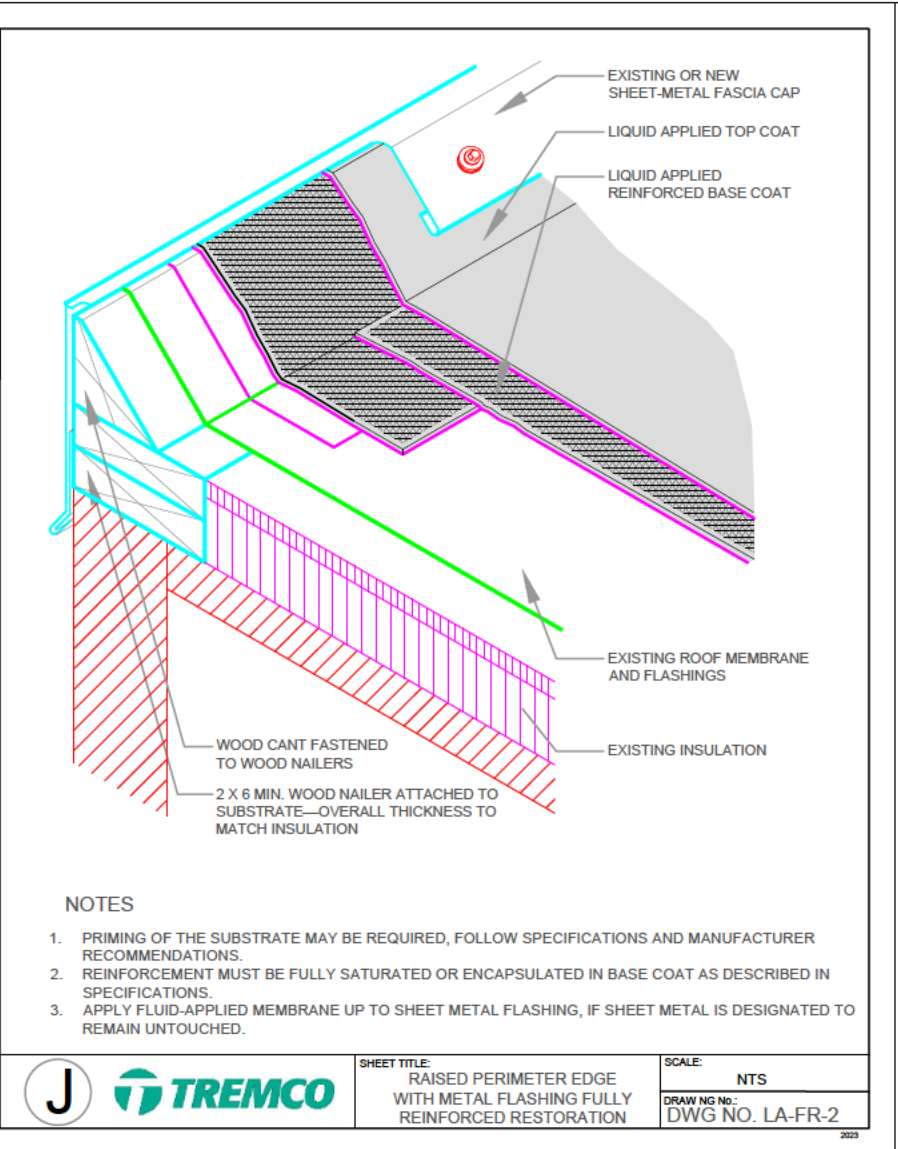
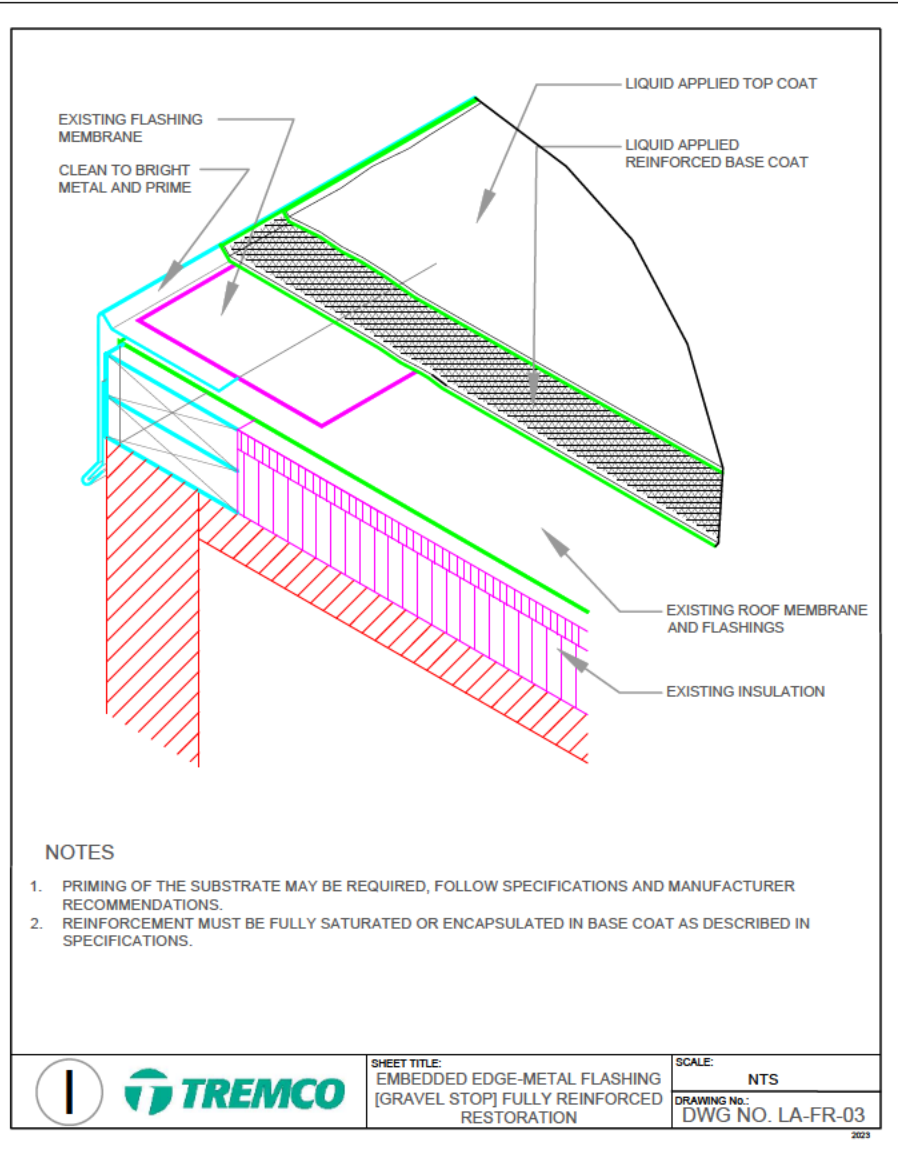
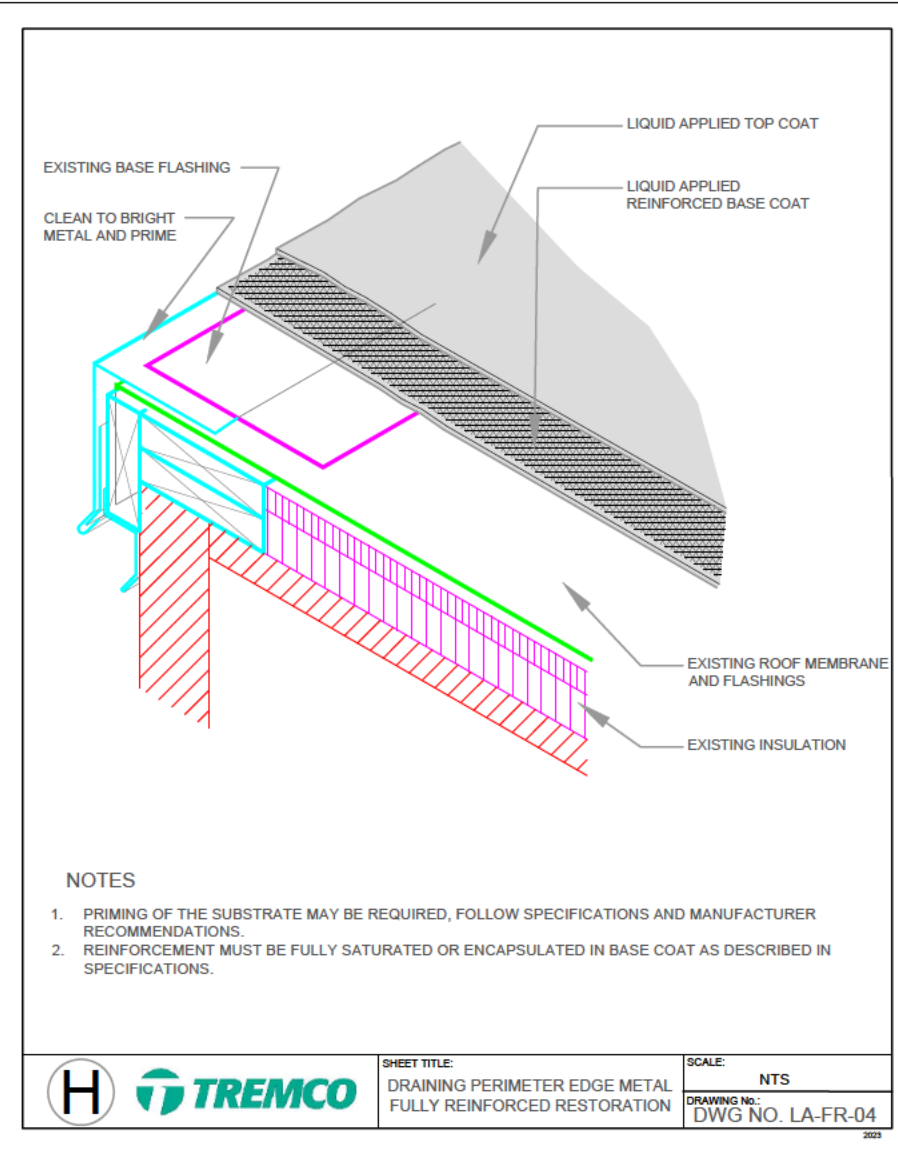
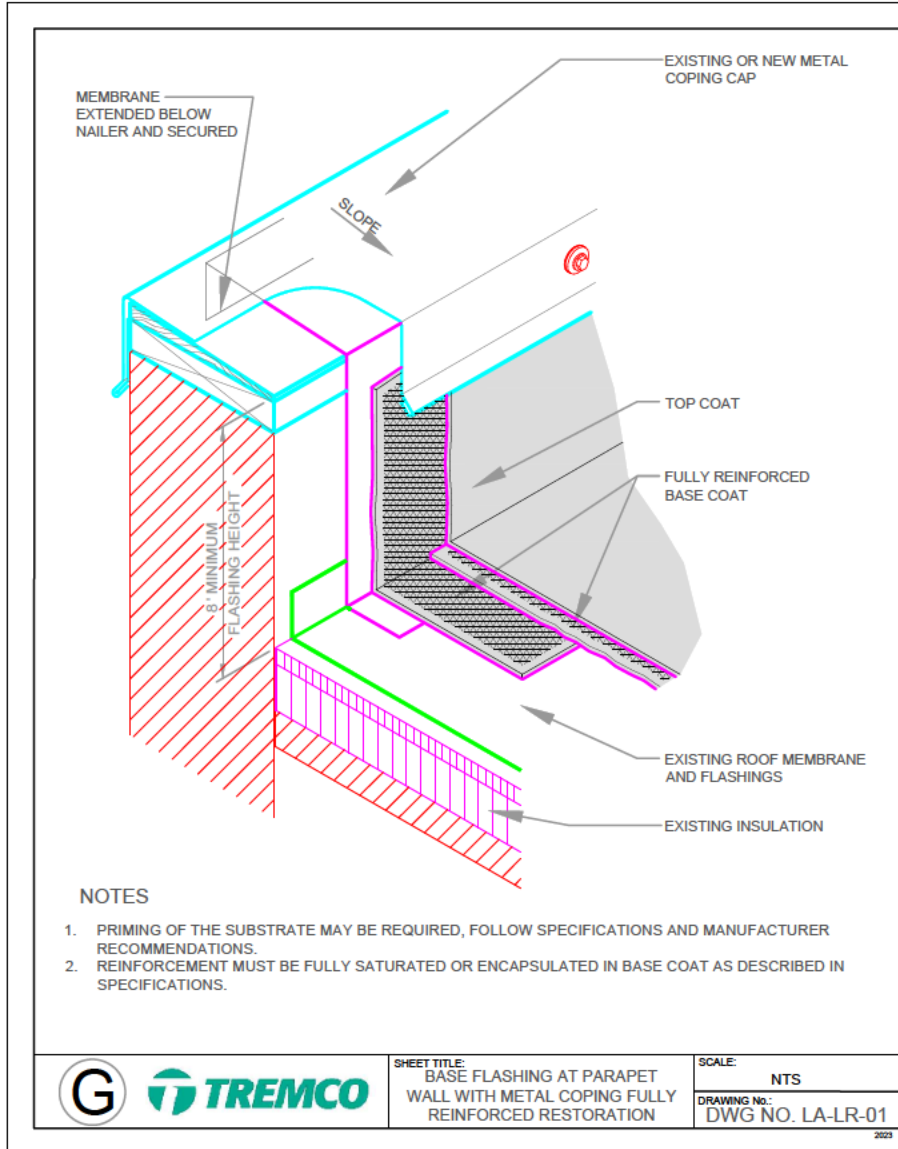
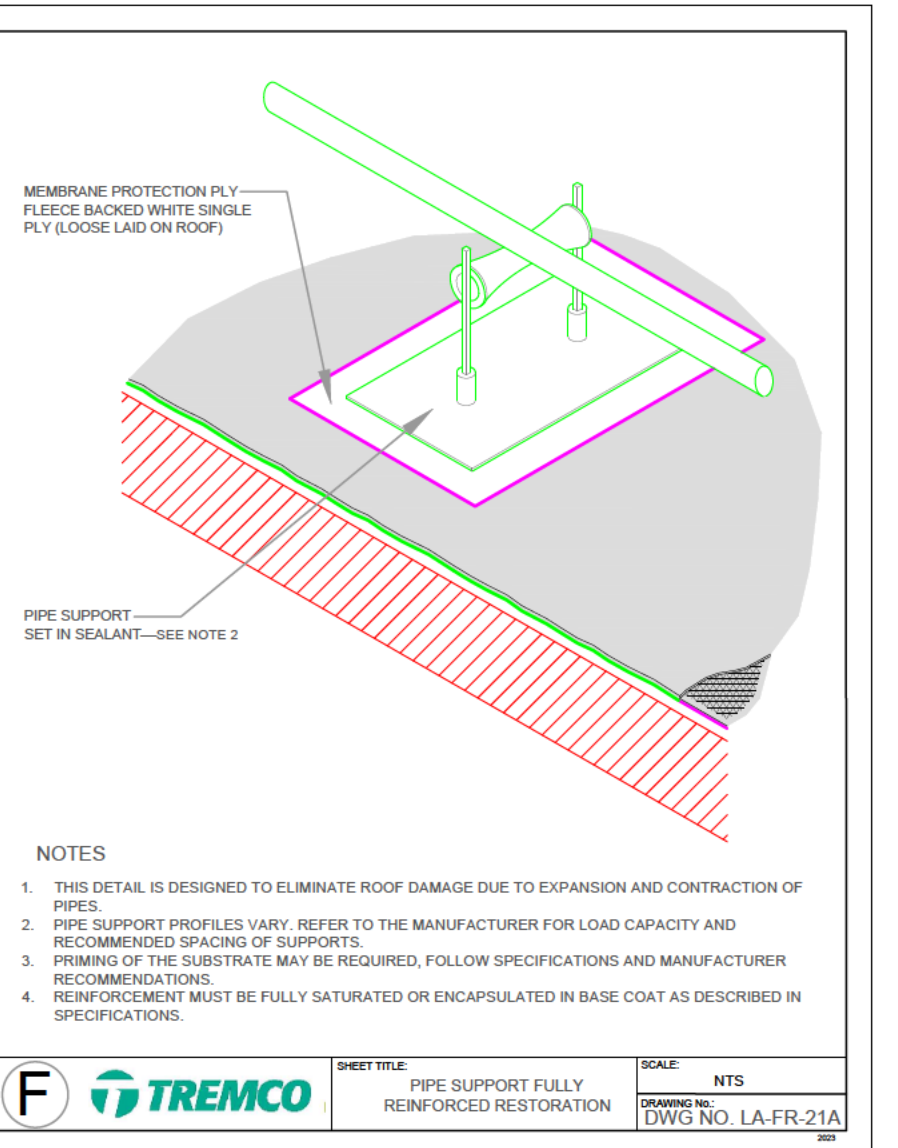
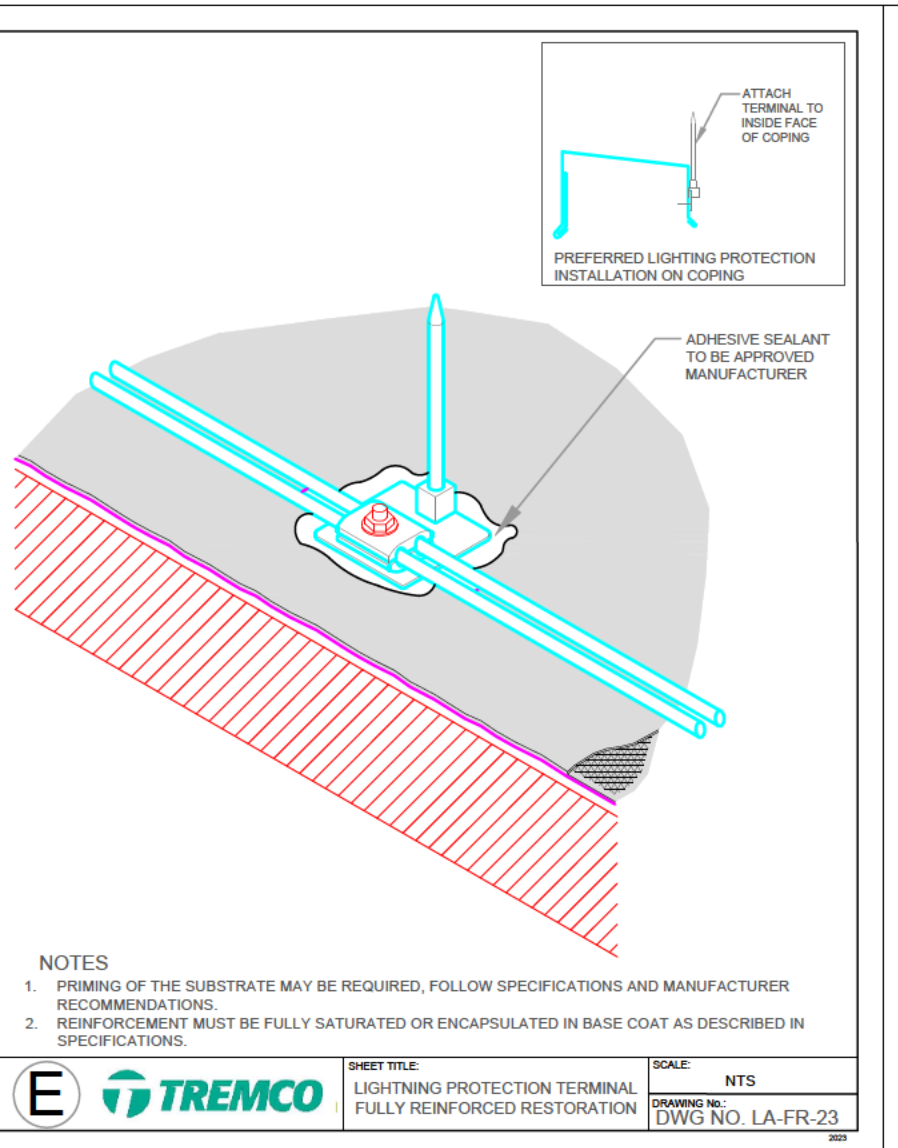
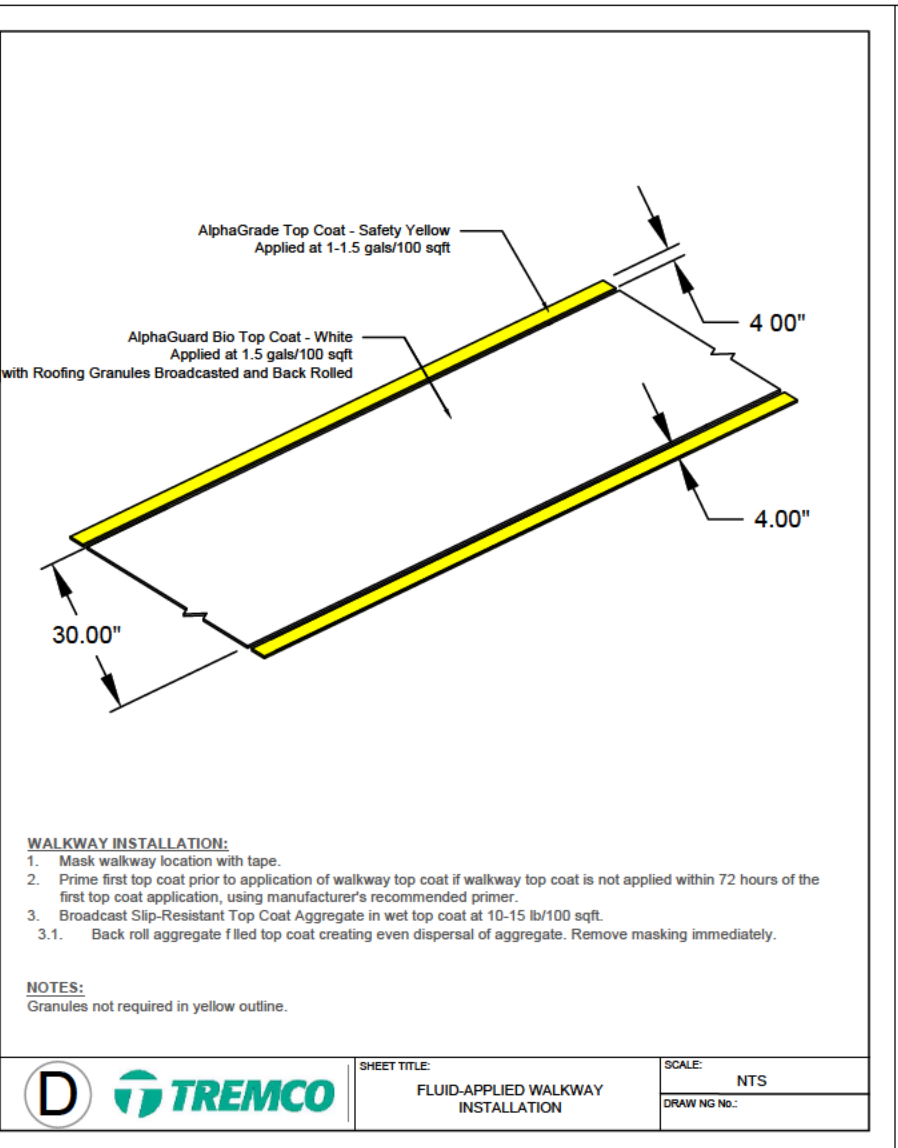
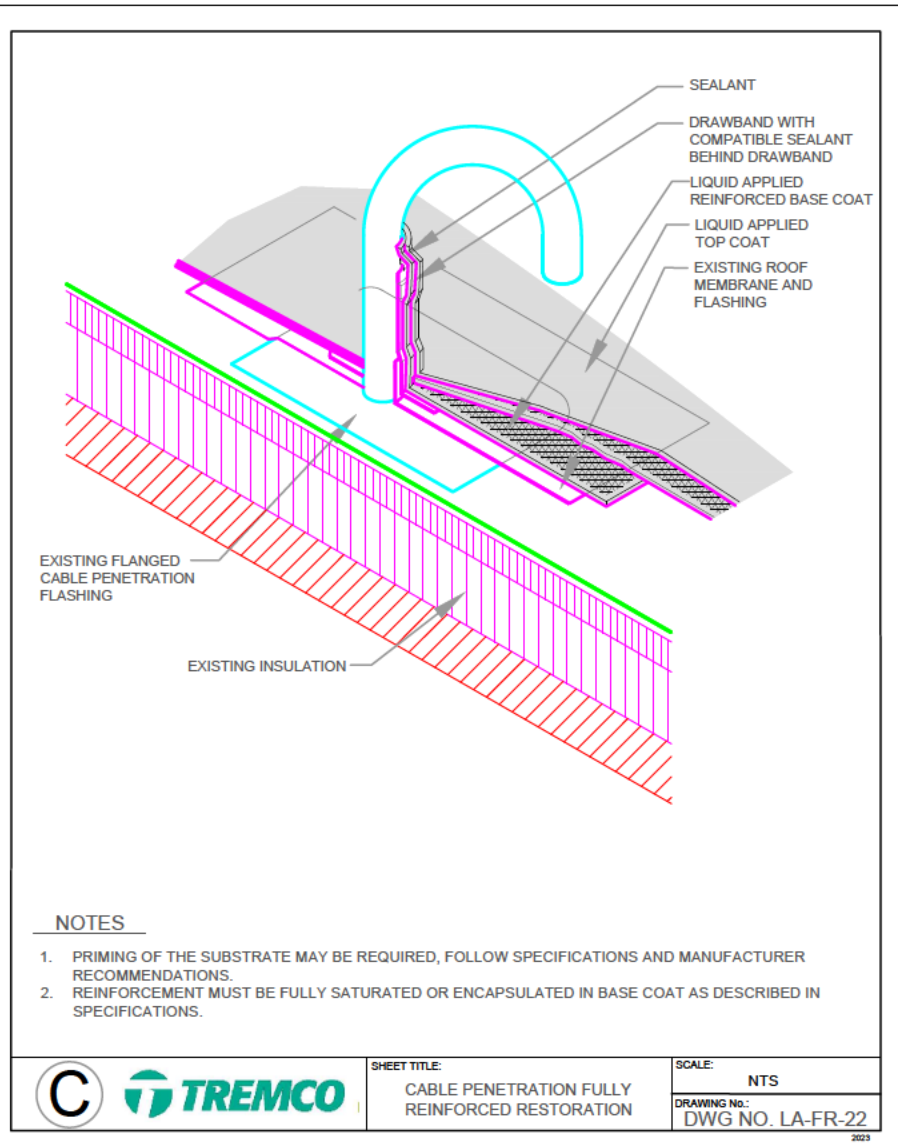
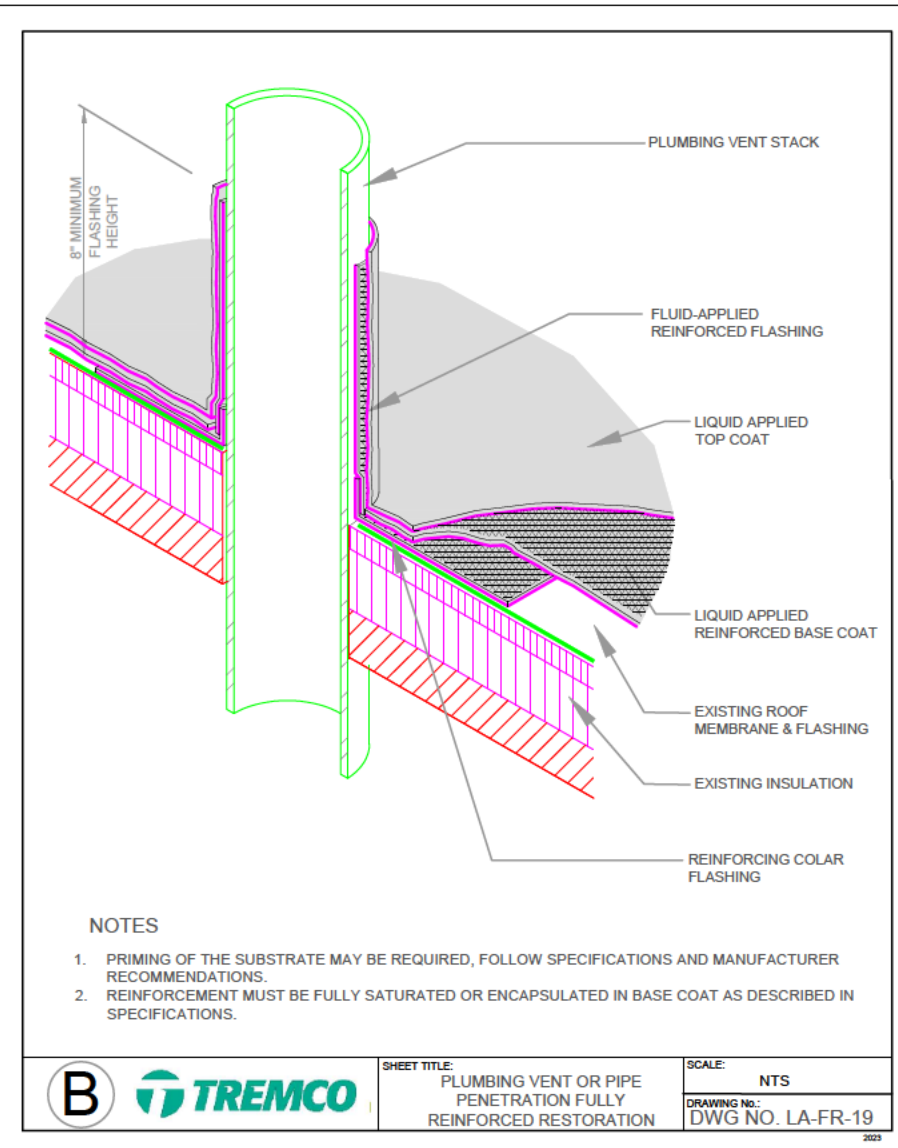
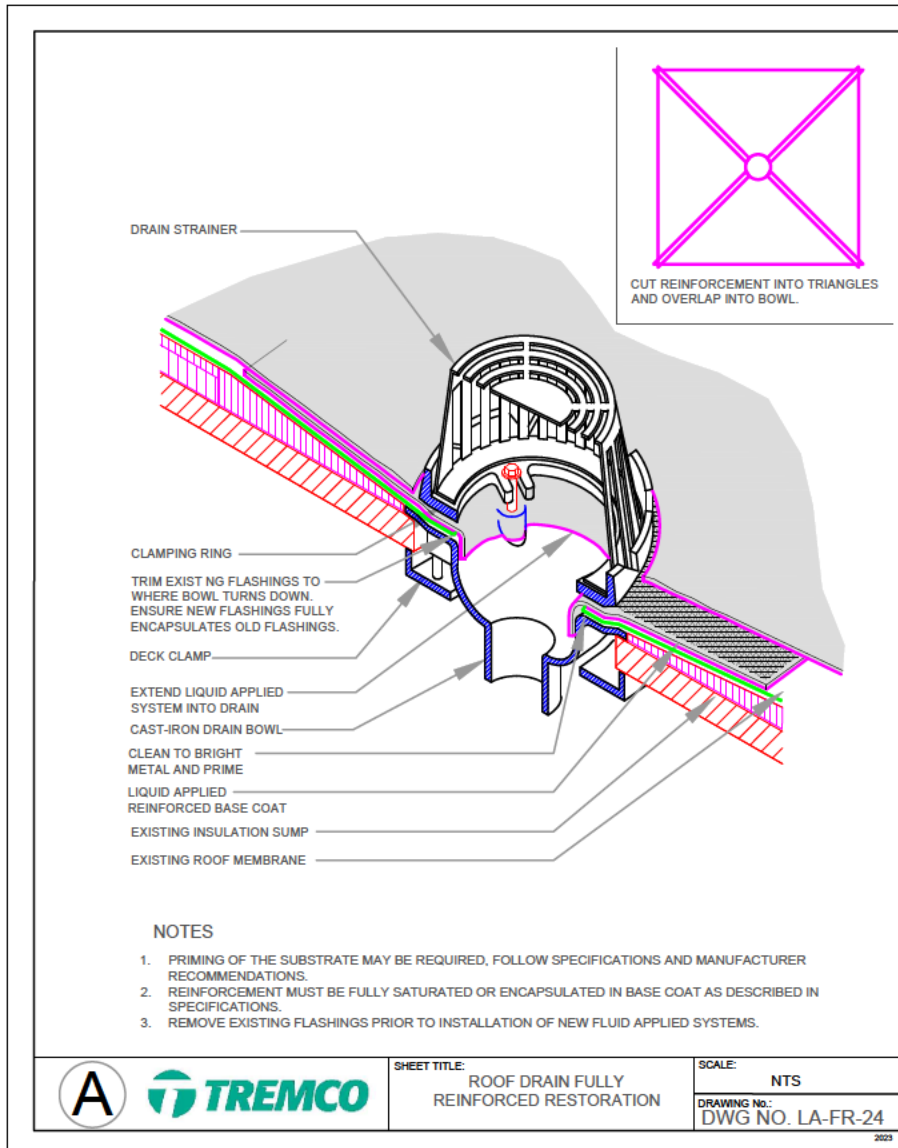

TREMCO

Drawing Title:
Fluid-Applied Restoration
Typical Details

Project Notes:

Project Number:

Date: MAY_2026

Sheet Number: D-1

Roof Diagnostic Survey – 2/23/26

DuPage County

501 Building

421 N. County Farm Rd., Wheaton, IL 60187

Understanding Building Roof Infrared Imagery & Nuclear Surveys

1-20 = Dry, 21 & Above = Wet

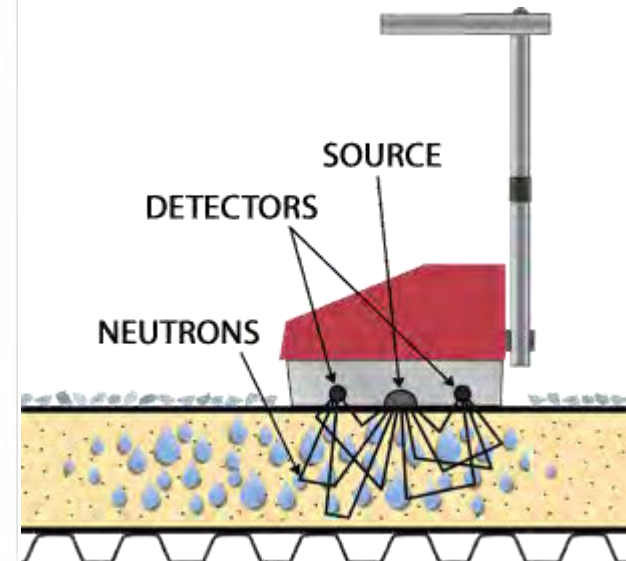
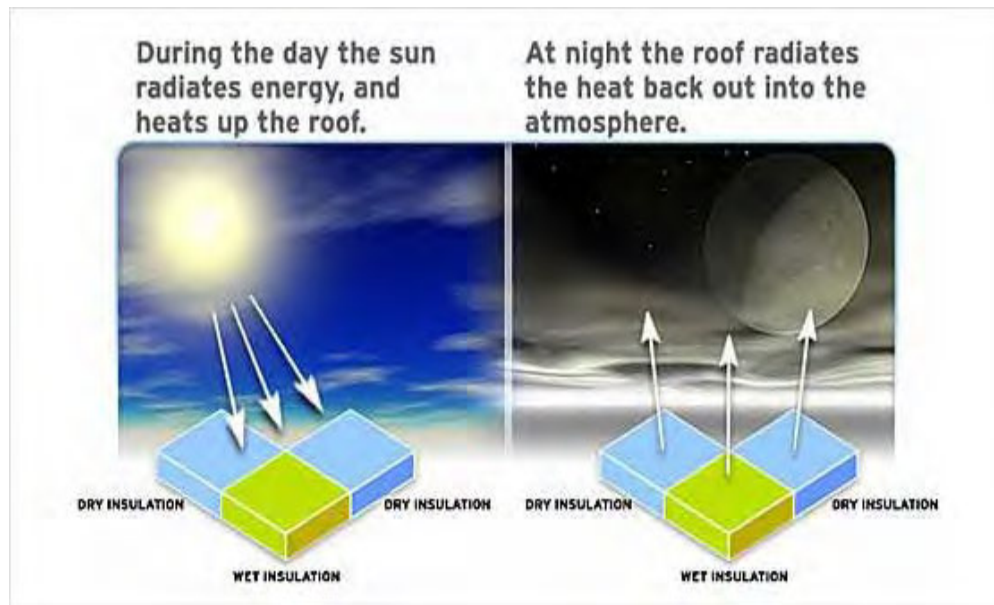

2149 Potter Rd. E.
Traverse City, MI 49696
231.590.9899
www.irtroofing.com



Understanding Nuclear Surveys

A nuclear roof moisture survey is the only effective method for locating areas of wet insulation within a ballasted roof system or multi-layered roof assembly. A nuclear gauge is used to detect varying levels of hydrogen ions within the roof system, with hydrogen being most abundant in wet materials. Readings are taken in conjunction with physical sampling to determine a baseline reading for dry materials. Typically readings are taken on a 10'x10' grid pattern and transferred to a scaled roof plan showing a visual representation of the wet areas. Readings over the dry baseline benchmark indicate damp to wet materials, with moisture content increasing with higher readings.

Inspector: Len Simkins

Phone: (231) 590-9899

This report provides the inspector's opinion of the condition of the elements inspected. The findings are based on a limited time/scope inspection performed according to the terms of Infrared Roofing Technologies and in a manner consistent with property inspection industry standards. The inspection is limited to readily accessible systems or components of the property. No guarantees are implied with respect to future deficiencies or conditions. No engineering, geological, design, environmental, biological, health related or code compliance evaluations of the property were performed. The information in this report was prepared exclusively for the named client and/or their authorized representative. The report, including supplemental information and addenda should be reviewed in its entirety.

Comments: Overall, the roof sections had 236 SF of wet insulation which is detailed in the report. Thank you for allowing Infrared Roofing Technologies to perform a Nuclear inspection of your facility. If you have any questions please do not hesitate to call or e-mail me.

Thanks again – Len Simkins

RSO & Level III Thermographer

2149 Potter Rd. E.
Traverse City, MI 49696
231.590.9899
www.irtroofing.com

IRT

INFRARED | ROOFING | TECHNOLOGIES

"Revealing the Hidden Truth"



2149 Potter Rd. E.
Traverse City, MI 49696
231.590.9899
www.irtroofing.com

IRT

INFRARED | ROOFING | TECHNOLOGIES

“Revealing the Hidden Truth”

Overview Photos

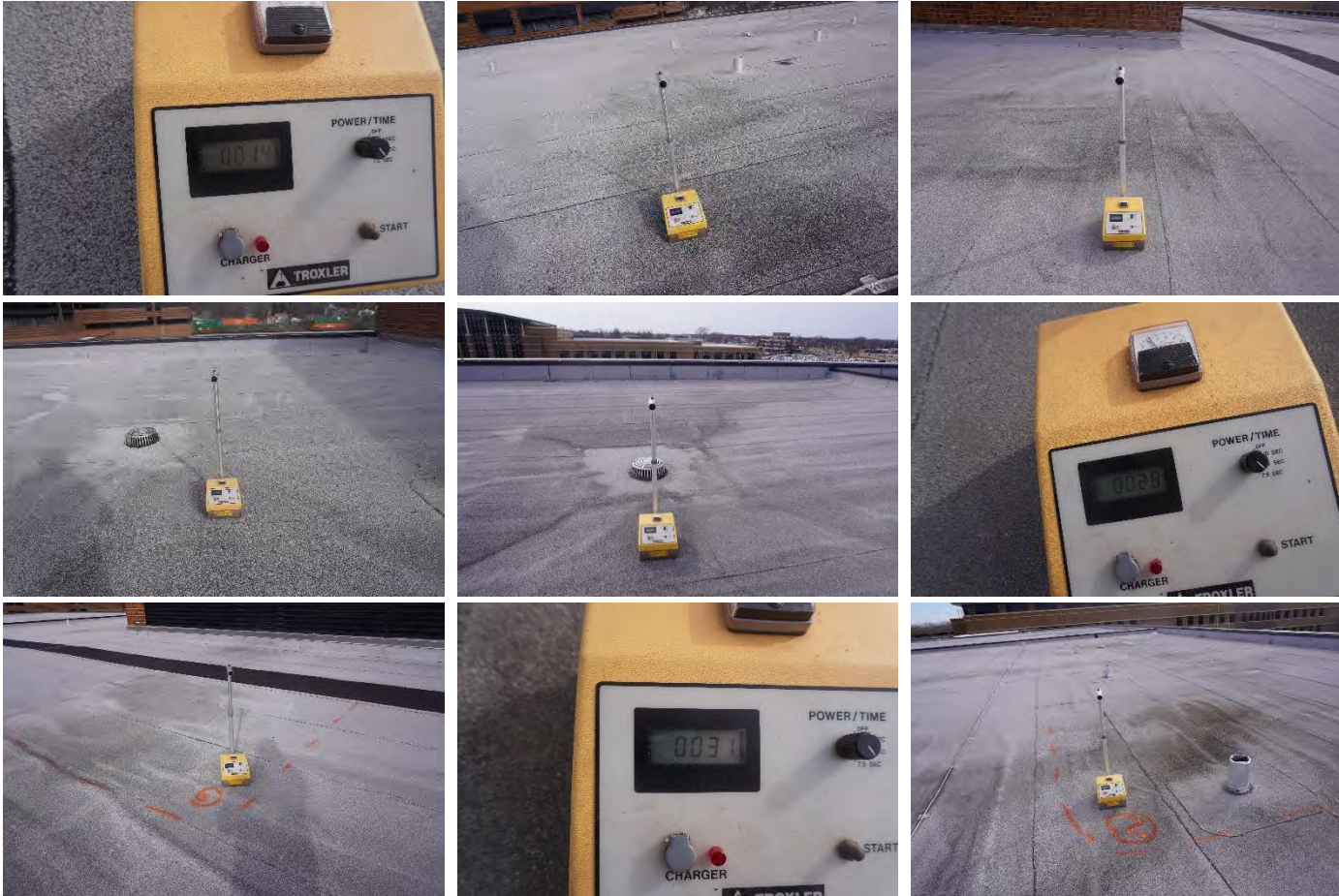

2149 Potter Rd. E.
Traverse City, MI 49696
231.590.9899
www.irtroofing.com

IRT

INFRARED | ROOFING | TECHNOLOGIES
"Revealing the Hidden Truth"

Overview Photos



2149 Potter Rd. E.
Traverse City, MI 49696
231.590.9899
www.irtroofing.com

Region 4 Education Service Center (ESC)

Contract # R230404

for

ROOFING PRODUCTS, SERVICES AND JOB-ORDER-
CONTRACTING (JOC) SERVICES

with

Weatherproofing Technologies Inc.

Effective: November 1,2023

The following documents comprise the executed contract between the Region 4 Education Service Center and Weatherproofing Technologies Inc effective November 1, 2023:

- I. Vendor Contract and Signature Form
- II. Supplier's Response to the RFP, incorporated by reference

CONTRACT

*This Contract ("**Contract**") is made as of November 1, 2023, by and between Weatherproofing Technologies Inc. ("**Contractor**") and Region 4 Education Service Center ("**Region 4 ESC**") for the purchase of Roofing Products, Services, & Job-Order-Contracting (JOC) Services ("the products and services").*

RECITALS

WHEREAS, Region 4 ESC issued Request for Proposals Number 23-04 for Roofing Products, Services, & Job-Order-Contracting (JOC) Services ("the products and services") ("RFP"), to which Contractor provided a response ("**Proposal**"); and

WHEREAS, Region 4 ESC selected Contractor's Proposal and wishes to engage Contractor in providing the services/materials described in the RFP and Proposal;

WHEREAS, both parties agree and understand the following pages will constitute the Contract between the Contractor and Region 4 ESC, having its principal place of business at 7145 West Tidwell Road, Houston, TX 77092.

WHEREAS, Contractor included, in writing, any required exceptions or deviations from these terms, conditions, and specifications; and it is further understood that, if agreed to by Region 4 ESC, said exceptions or deviations are incorporated into the Contract.

WHEREAS, this Contract consists of the provisions set forth below, including provisions of all attachments referenced herein. In the event of a conflict between the provisions set forth below and those contained in any attachment, the provisions set forth below shall control.

WHEREAS, the Contract will provide that any state and local governmental entities, public and private primary, secondary and higher education entities, non-profit entities, and agencies for the public benefit ("**Public Agencies**") may purchase products and services at prices indicated in the Contract upon the Public Agency's registration with OMNIA Partners.

- 1) Term of agreement. The initial term of the Contract is for a period of three (3) years unless terminated, canceled or extended as otherwise provided herein. Region 4 ESC shall have the right in its sole discretion to renew the Contract for an additional term of up to two (2) years or for a lesser period of time as determined by Region 4 ESC by providing written notice to the Contractor of Region 4 ESC's intent to renew thirty (30) days prior to the expiration of the original term. Contractor acknowledges and understands Region 4 ESC is under no obligation whatsoever to extend the term of this Contract. Notwithstanding the forgoing paragraph, the term of the Contract, including any extension of the original term, shall be further extended until the expiration of any Purchase Order issued under the Contract for a period of up to one year beyond the Contract term.
- 2) Scope: Contractor shall perform all duties, responsibilities and obligations, set forth in this agreement, and described in the RFP, incorporated herein by reference as though fully set forth herein.

- 3) Form of Contract. The form of Contract shall be the RFP, the Offeror's proposal and Best and Final Offer(s).
- 4) Order of Precedence. In the event of a conflict in the provisions of the Contract as accepted by Region 4 ESC, the following order of precedence shall prevail:
 - i. This Contract
 - ii. Offeror's Best and Final Offer
 - iii. Offeror's proposal
 - iv. RFP and any addenda
- 5) Commencement of Work. The Contractor is cautioned not to commence any billable work or provide any material or service under this Contract until Contractor receives a purchase order for such work or is otherwise directed to do so in writing by Region 4 ESC.
- 6) Entire Agreement (Parol evidence). The Contract, as specified above, represents the final written expression of agreement. All agreements are contained herein and no other agreements or representations that materially alter it are acceptable.
- 7) Assignment of Contract. No assignment of Contract may be made without the prior written approval of Region 4 ESC. Contractor is required to notify Region 4 ESC when any material change in operations is made (i.e., bankruptcy, change of ownership, merger, etc.).
- 8) Novation. If Contractor sells or transfers all assets or the entire portion of the assets used to perform this Contract, a successor in interest must guarantee to perform all obligations under this Contract. Region 4 ESC reserves the right to accept or reject any new party. A change of name agreement will not change the contractual obligations of Contractor.
- 9) Contract Alterations. No alterations to the terms of this Contract shall be valid or binding unless authorized and signed by Region 4 ESC.
- 10) Adding Authorized Distributors/Dealers.

The National Cooperative Contractor Network roster lists the individual pre-qualified and In-Network contractors that are independently owned and part of this RFP response. This roster will be updated as new contractors enter the program who demonstrate competency in the stipulated criteria and that agree to the terms and conditions contained in this RFP. Contractors accepted in the Contractor Network Program will be sent to Region 4 ESC for approval prior to performing work for OMNIA Members.

Under the Contractor Network Method of Delivery, which is included in our response, the awarded In-Network contractor is the prime. All POs, invoices, payments, etc. will occur directly between the In-Network Contractor and the Participating Public Agency directly.

11) TERMINATION OF CONTRACT

- a) Cancellation for Non-Performance or Contractor Deficiency. Region 4 ESC may terminate the Contract if purchase volume is determined to be low volume in any 12-month period. Region 4 ESC reserves the right to cancel the whole or any part of this Contract due to failure by Contractor to carry out any obligation, term or condition of the contract. Region 4 ESC may issue a written deficiency notice to Contractor for acting or failing to act in any of the following:

- i. Providing material that does not meet the specifications of the Contract;
- ii. Providing work or material was not awarded under the Contract;
- iii. Failing to adequately perform the services set forth in the scope of work and specifications;
- iv. Failing to complete required work or furnish required materials within a reasonable amount of time;
- v. Failing to make progress in performance of the Contract or giving Region 4 ESC reason to believe Contractor will not or cannot perform the requirements of the Contract; or
- vi. Performing work or providing services under the Contract prior to receiving an authorized purchase order.

Upon receipt of a written deficiency notice, Contractor shall have ten (10) days to provide a satisfactory response to Region 4 ESC. Failure to adequately address all issues of concern may result in Contract cancellation. Upon cancellation under this paragraph, all goods, materials, work, documents, data and reports prepared by Contractor under the Contract shall immediately become the property of Region 4 ESC.

- b) Termination for Cause. If, for any reason, Contractor fails to fulfill its obligation in a timely manner, or Contractor violates any of the covenants, agreements, or stipulations of this Contract Region 4 ESC reserves the right to terminate the Contract immediately and pursue all other applicable remedies afforded by law. Such termination shall be effective by delivery of notice, to the Contractor, specifying the effective date of termination. In such event, all documents, data, studies, surveys, drawings, maps, models and reports prepared by Contractor will become the property of the Region 4 ESC. If such event does occur, Contractor will be entitled to receive just and equitable compensation for the satisfactory work completed on such documents.
- c) Delivery/Service Failures. Failure to deliver goods or services within the time specified, or within a reasonable time period as interpreted by the purchasing agent or failure to make replacements or corrections of rejected articles/services when so requested shall constitute grounds for the Contract to be terminated. In the event Region 4 ESC must purchase in an open market, Contractor agrees to reimburse Region 4 ESC, within a reasonable time period, for all expenses incurred.
- d) Force Majeure. If by reason of Force Majeure, either party hereto shall be rendered unable wholly or in part to carry out its obligations under this Agreement then such party shall give notice and full particulars of Force Majeure in writing to the other party within a reasonable time after occurrence of the event or cause relied upon, and the obligation of the party giving such notice, so far as it is affected by such Force Majeure, shall be suspended during the continuance of the inability then claimed, except as hereinafter provided, but for no longer period, and such party shall endeavor to remove or overcome such inability with all reasonable dispatch.

The term Force Majeure as employed herein, shall mean acts of God, strikes, lockouts, or other industrial disturbances, act of public enemy, orders of any kind of government of the United States or the State of Texas or any civil or military authority; insurrections; riots; epidemics; landslides; lighting; earthquake; fires; hurricanes; storms; floods; washouts; droughts; arrests; restraint of government and people; civil disturbances; explosions, breakage or accidents to machinery, pipelines or canals, or other causes not reasonably within the control of the party claiming such inability. It is understood and agreed that the settlement of strikes and lockouts shall be entirely within the discretion of the party having the difficulty, and that the above requirement that any Force Majeure shall be remedied with all reasonable dispatch shall not require the settlement of strikes and lockouts by acceding to the demands of the opposing party or parties when such settlement is unfavorable in the judgment of the party having the difficulty.

- e) Standard Cancellation. Region 4 ESC may cancel this Contract in whole or in part by providing written notice. The cancellation will take effect 30 business days after the other party receives the notice of cancellation. After the 30th business day all work will cease following completion of final purchase order.
- 12) Licenses. Contractor shall maintain in current status all federal, state and local licenses, bonds and permits required for the operation of the business conducted by Contractor. Contractor shall remain fully informed of and in compliance with all ordinances and regulations pertaining to the lawful provision of services under the Contract. Region 4 ESC reserves the right to stop work and/or cancel the Contract if Contractor's license(s) expire, lapse, are suspended or terminated.
- 13) Survival Clause. All applicable software license agreements, warranties or service agreements that are entered into between Contractor and Region 4 ESC under the terms and conditions of the Contract shall survive the expiration or termination of the Contract. Proposals submitted to OMNIA Members prior to expiration or termination of the contract that lead to the issuance of a purchase order will survive the term of the agreement. All Purchase Orders issued and accepted by Contractor shall survive expiration or termination of the Contract for a period of up to one year beyond the term of the Contract.
- 14) Delivery. Conforming product shall be shipped within 7 days of receipt of Purchase Order. If delivery is not or cannot be made within this time period, the Contractor must receive authorization for the delayed delivery. The order may be canceled if the estimated shipping time is not acceptable. All deliveries shall be freight prepaid, and freight pricing will be provided on each proposal.
- 15) Inspection & Acceptance. If defective or incorrect material is delivered, Region 4 ESC may make the determination to return the material to the Contractor at no cost to Region 4 ESC. The Contractor agrees to pay all shipping costs for the return shipment. Contractor shall be responsible for arranging the return of the defective or incorrect material.
- 16) Payments. Payment shall be made after satisfactory performance, in accordance with all provisions thereof, and upon receipt of a properly completed invoice.
- 17) Price Adjustments. Should it become necessary or proper during the term of this Contract to make any change in design or any alterations that will increase price, Region 4 ESC must be notified immediately. Price increases must be approved by Region 4 ESC and no payment for additional materials or services, beyond the amount stipulated in the Contract shall be paid without prior approval. All price increases must be supported by manufacturer documentation, or a formal cost justification letter. Contractor must honor previous prices for thirty (30) days after approval and written notification from Region 4 ESC. It is the Contractor's responsibility to keep all pricing up to date and on file with Region 4 ESC. All price changes must be provided to Region 4 ESC, using the same format as was provided and accepted in the Contractor's proposal.

Price reductions may be offered at any time during Contract. Special, time-limited reductions are permissible under the following conditions: 1) reduction is available to all users equally; 2) reduction is for a specific period, normally not less than thirty (30) days; and 3) original price is not exceeded after the time-limit. Contractor shall offer Region 4 ESC any published price reduction during the Contract term.

- 18) Audit Rights. Contractor shall, at its sole expense, maintain appropriate due diligence of all purchases made by Region 4 ESC and any entity that utilizes this Contract. Region 4 ESC reserves the right to audit the accounting for a period of three (3) years from the time such purchases are made. This audit right shall survive termination of this Agreement for a period of one (1) year from the effective date of termination. Region 4 ESC shall have the authority to conduct random audits of Contractor's pricing at Region 4 ESC's sole cost and expense. Notwithstanding the foregoing, in the event that Region 4 ESC is made aware of any pricing being offered that is materially inconsistent with the pricing under this agreement, Region 4 ESC shall have the ability to conduct an extensive audit of Contractor's pricing at Contractor's sole cost and expense. Region 4 ESC may conduct the audit internally or may engage a third-party auditing firm. In the event of an audit, the requested materials shall be provided in the format and at the location designated by Region 4 ESC.
- 19) Discontinued Products. If a product or model is discontinued by the manufacturer, Contractor may substitute a new product or model if the replacement product meets or exceeds the specifications and performance of the discontinued model and if the discount is the same or greater than the discontinued model.
- 20) New Products/Services. New products and/or services that meet the scope of work may be added to the Contract. Pricing shall be equivalent to the percentage discount for other products. Contractor may replace or add product lines if the line is replacing or supplementing products, is equal or superior to the original products, is discounted similarly or greater than the original discount, and if the products meet the requirements of the Contract. No products and/or services may be added to avoid competitive procurement requirements. Region 4 ESC may require additions to be submitted with documentation from Members demonstrating an interest in, or a potential requirement for, the new product or service. Region 4 ESC may reject any additions without cause.
- 21) Options. Optional equipment for products under Contract may be added to the Contract at the time they become available under the following conditions: 1) the option is priced at a discount similar to other options; 2) the option is an enhancement to the unit that improves performance or reliability.
- 22) Warranty Conditions. All supplies, equipment and services shall include manufacturer's minimum standard warranty and one (1) year labor warranty unless otherwise agreed to in writing.
- 23) Site Cleanup. Contractor shall clean up and remove all debris and rubbish resulting from their work as required or directed. Upon completion of the work, the premises shall be left in good repair and an orderly, neat, clean, safe and unobstructed condition.
- 24) Site Preparation. Contractor shall not begin a project for which the site has not been prepared, unless Contractor does the preparation work at no cost, or until Region 4 ESC includes the cost of site preparation in a purchase order. Site preparation includes, but is not limited to moving furniture, installing wiring for networks or power, and similar pre-installation requirements.
- 25) Registered Sex Offender Restrictions. For work to be performed at schools, Contractor agrees no employee or employee of a subcontractor who has been adjudicated to be a registered sex offender will perform work at any time when students are or are reasonably expected to be present. Contractor agrees a violation of this condition shall be considered a

material breach and may result in the cancellation of the purchase order at Region 4 ESC's discretion. Contractor must identify any additional costs associated with compliance of this term. If no costs are specified, compliance with this term will be provided at no additional charge.

- 26) Safety measures. Contractor shall take all reasonable precautions for the safety of employees on the worksite and shall erect and properly maintain all necessary safeguards for protection of workers and the public. Contractor shall post warning signs against all hazards created by its operation and work in progress. Proper precautions shall be taken pursuant to state law and standard practices to protect workers, general public and existing structures from injury or damage.
- 27) Smoking. Persons working under the Contract shall adhere to local smoking policies. Smoking will only be permitted in posted areas or off premises.
- 28) Stored materials. Upon prior written agreement between the Contractor and Region 4 ESC, payment may be made for materials not incorporated in the work but delivered and suitably stored at the site or some other location, for installation at a later date. An inventory of the stored materials must be provided to Region 4 ESC prior to payment. Such materials must be stored and protected in a secure location and be insured for their full value by the Contractor against loss and damage. Contractor agrees to provide proof of coverage and additionally insured upon request. Additionally, if stored offsite, the materials must also be clearly identified as property of Region 4 ESC and be separated from other materials. Region 4 ESC must be allowed reasonable opportunity to inspect and take inventory of stored materials, on or offsite, as necessary. Until final acceptance by Region 4 ESC, it shall be the Contractor's responsibility to protect all materials and equipment. Contractor warrants and guarantees that title for all work, materials and equipment shall pass to Region 4 ESC upon final acceptance.
- 29) Funding Out Clause. A Contract for the acquisition, including lease, of real or personal property is a commitment of Region 4 ESC's current revenue only. Region 4 ESC retains the right to terminate the Contract at the expiration of each budget period during the term of the Contract and is conditioned on a best effort attempt by Region 4 ESC to obtain appropriate funds for payment of the contract.
- 30) Indemnity. Contractor shall protect, indemnify, and hold harmless both Region 4 ESC and its administrators, employees and agents against all claims, damages, losses and expenses arising out of or resulting from the actions of the Contractor, Contractor employees or subcontractors in the preparation of the solicitation and the later execution of the Contract. Any litigation involving either Region 4 ESC, its administrators and employees and agents will be in Harris County, Texas.
- 31) Marketing. Contractor agrees to allow Region 4 ESC to use their name and logo within website, marketing materials and advertisement. Any use of Region 4 ESC name and logo or any form of publicity, inclusive of press releases, regarding this Contract by Contractor must have prior approval from Region 4 ESC.
- 32) Certificates of Insurance. Certificates of insurance shall be delivered to the Region 4 ESC prior to commencement of work. The Contractor shall give Region 4 ESC a minimum of ten (10) days' notice prior to any modifications or cancellation of policies. The Contractor shall require all subcontractors performing any work to maintain coverage as specified.

33) Legal Obligations. It is Contractor's responsibility to be aware of and comply with all local, state, and federal laws governing the sale of products/services and shall comply with all laws while fulfilling the Contract. Applicable laws and regulation must be followed even if not specifically identified herein.

OFFER AND CONTRACT SIGNATURE FORM

The undersigned hereby offers and, if awarded, agrees to furnish goods and/or services in strict compliance with the terms, specifications and conditions at the prices proposed within response unless noted in writing.

Company Name Weatherproofing Technologies Inc.

Address 3735 Green Rd.

City/State/Zip Beachwood, OH 44122

Telephone No. (216) 292-5064

Email Address JKMilliken@tremcoinc.com

Printed Name JK Milliken

Title President

Authorized signature 

Accepted by Region 4 ESC:

Contract No. R230404

Initial Contract Term 11/1/2023 to 10/31/2026

Region 4 ESC Authorized Board Member

10/24/2023
Date

Print Name

Region 4 ESC Authorized Board Member

10/24/2023
Date

Print Name

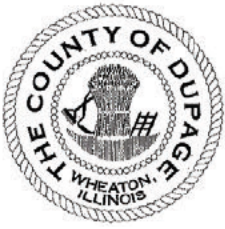

REQUIRED VENDOR ETHICS DISCLOSURE STATEMENT

Section I: Contact Information

Please complete the contact information below.

BID NUMBER:	
COMPANY NAME:	Malcor Roofing of Illinois Inc.
CONTACT PERSON:	Jason Doran
CONTACT EMAIL:	jason@malcorroofing.com

Section II: Procurement Ordinance Requirements

Every contractor, union, or vendor that is seeking or has previously obtained a contract, change orders to one (1) or more contracts, or two (2) or more individual contracts with the County, shall provide to the Procurement Division a written disclosure of all political campaign contributions made by such contractor, union, or vendor to any incumbent County Board member, County Board chairman, or Countywide elected official whose office the contract to be awarded will benefit within the current and previous calendar year. The contractor, union, or vendor shall update such disclosure annually during the term of a multi-year contract and prior to any change order or renewal requiring approval by the county board. For purposes of this disclosure requirement, "contractor or vendor" includes owners, officers, managers, lobbyists, agents, consultants, bond counsel and underwriters counsel, subcontractors, and corporate entities under the control of the contracting person, and political action committees to which the contracting person has made contributions.

Has the Bidder made contributions as described above?

- Yes
 No

If "Yes", complete the required information in the table below.

RECIPIENT	DONOR	DESCRIPTION (e.g., cash, type of item, in-kind services, etc.)	AMOUNT/VALUE	DATE MADE

All contractors and vendors who have obtained or are seeking contracts with the County shall disclose the names and contact information of their lobbyists, agents and representatives and all individuals who are or will be having contact with county officers or employees in relation to the contractor bid and shall update such disclosure with any changes that may occur.

Has the Bidder had or will the Bidder have contact with lobbyists, agents, representatives or individuals who are or will be having contact with county officers or employees as described above.

Yes

No

If "Yes", list the name, phone number, and email of lobbyists, agents, representatives, and all individuals who are or will be having contact with county officers or employees in the table below.

NAME	PHONE	EMAIL

Section III: Violations

A contractor or vendor that knowingly violates these disclosure requirements is subject to penalties which may include, but are not limited to, the immediate cancellation of the contract and possible disbarment from future County contracts. Continuing and supplemental disclosure is required. The Bidder agrees to update this disclosure form as follows:

- If information changes, within five (5) days of change, or prior to county action, whichever is sooner;
- 30 days prior to the optional renewal of any contract;
- Annual disclosure for multi-year contracts on the anniversary of said contract
- With any request for change order except those issued by the county for administrative adjustments

The full text of the County's Ethics Ordinance is available at:

[Ethics | DuPage Co, IL](#)

The full text of the County's Procurement Ordinance is available at:

[ARTICLE VI. - PROCUREMENT | Code of Ordinances | DuPage County, IL | Municode Library](#)

Section IV: Certification

By signing below, the Bidder hereby acknowledges that it has received, read, and understands these requirements, and certifies that the information submitted on this form is true and correct to the best of its knowledge.

Printed Name: Jason Doran Signature: 

Title: VP Date: 6/9/2026



File #: FM-P-0023-26

Agenda Date: 7/7/2026

Agenda #: 9.C.

AWARDING RESOLUTION
ISSUED TO DESIGN DEVELOPERS & REHUB INC.,
FOR THE DUPAGE COUNTY HISTORICAL MUSEUM
FRONT ENTRANCE STAIRS REPLACEMENT
FOR FACILITIES MANAGEMENT
(CONTRACT TOTAL NOT TO EXCEED (\$287,100.00))

WHEREAS, bids have been taken and processed in accordance with County Board policy; and

WHEREAS, the Public Works Committee recommends County Board approval for the issuance of a contract to Design Developers & Rehub Inc., for the DuPage County Historical Museum front entrance stairs replacement, for the period July 14, 2026 through July 13, 2027, for Facilities Management.

NOW, THEREFORE BE IT RESOLVED, that County Contract, covering said, or the DuPage County Historical Museum front entrance stairs replacement, for the period July 14, 2026 through July 13, 2027, for Facilities Management, be, and it is hereby approved for issuance of a contract by the Procurement Division to, Design Developers & Rehub Inc., 7600 Roosevelt Rd., Ste. 166, Forest Park, IL 60130, for a contract total amount not to exceed \$287,100.00, per lowest responsible bid #26-011-FM.

Enacted and approved this 14th day of July, 2026 at Wheaton, Illinois.

DEBORAH A. CONROY, CHAIR
DU PAGE COUNTY BOARD

Attest: _____

JEAN KACZMAREK, COUNTY CLERK



Procurement Review Comprehensive Checklist
 Procurement Services Division
 This form must accompany all Purchase Order Requisitions

SECTION 1: DESCRIPTION			
<i>General Tracking</i>		<i>Contract Terms</i>	
FILE ID#: 26-1856	RFP, BID, QUOTE OR RENEWAL #: 26-011-FM	INITIAL TERM WITH RENEWALS: OTHER	INITIAL TERM TOTAL COST: \$287,100.00
COMMITTEE: PUBLIC WORKS	TARGET COMMITTEE DATE: 07/07/2026	PROMPT FOR RENEWAL:	CONTRACT TOTAL COST WITH ALL RENEWALS: \$287,100.00
	CURRENT TERM TOTAL COST: \$287,100.00	MAX LENGTH WITH ALL RENEWALS: ONE YEAR	CURRENT TERM PERIOD: INITIAL TERM
<i>Vendor Information</i>		<i>Department Information</i>	
VENDOR: Design Developers & Rehub Inc.	VENDOR #:	DEPT: Facilities Management	DEPT CONTACT NAME: Brian Rovik
VENDOR CONTACT: John Maka	VENDOR CONTACT PHONE: 773-510-2502	DEPT CONTACT PHONE #: 630-407-5705	DEPT CONTACT EMAIL: brian.rovik2@dupagecounty.gov
VENDOR CONTACT EMAIL: jdesigndevelopers@yahoo.com	VENDOR WEBSITE:	DEPT REQ #:	
<i>Overview</i>			
DESCRIPTION Identify scope of work, item(s) being purchased, total cost and type of procurement (i.e., lowest bid, RFP, renewal, sole source, etc.). Recommendation for the approval of a contract to Design Developers & Rehub Inc, for the DuPage County Historical Museum front entrance stairs replacement, for Facilities Management, for the period July 14, 2026 through July 13, 2027, for a contract total amount not to exceed \$287,100.00 per lowest responsible bid #26-011-FM.			
JUSTIFICATION Summarize why this procurement is necessary and what objectives will be accomplished This project will replace the existing main entrance steps, handrailings, and other concrete at the DuPage County Historical Museum, as well as restore an existing fire egress stair. These improvements will enhance the safety of the thousands of annual public visitors that utilize the museum. It will also improve the winter accessibility and maintenance of the building's main entrance stair, which sits under an active gutter.			

SECTION 2: DECISION MEMO REQUIREMENTS	
DECISION MEMO NOT REQUIRED	Select an item from the following dropdown menu to identify why a Decision Memo (Section 3) is not required. LOWEST RESPONSIBLE QUOTE/BID (QUOTE < \$25,000, BID ≥ \$25,000; ATTACH TABULATION)
DECISION MEMO REQUIRED	Select an item from the following dropdown menu to identify why a Decision Memo (Section 3) is required.

SECTION 3: DECISION MEMO	
SOURCE SELECTION	Describe method used to select source.
RECOMMENDATION AND TWO ALTERNATIVES	Describe staff recommendation and provide justification. Identify at least 2 other options to accomplish this request, including status quo, (i.e., take no action).

SECTION 4: SOLE SOURCE MEMO/JUSTIFICATION

JUSTIFICATION	Select an item from the following dropdown menu to justify why this is a sole source procurement.
NECESSITY AND UNIQUE FEATURES	Describe the product or services that are not available from other vendors. Explain necessary and unique features or services. Attach letters from manufacturer, letters from distributor, warranties, licenses, or patents as needed. Be specific.
MARKET TESTING	List and describe the last time the market has been tested on the applicability of the sole source. If it has not been tested over the last 12 months, explain why not.
AVAILABILITY	Describe steps taken to verify that these features are not available elsewhere. Included a detailed list of all products or services by brand/manufacturer examined and include names, phone numbers, and emails of people contacted.

SECTION 5: Purchase Requisition Information

<i>Send Purchase Order To:</i>		<i>Send Invoices To:</i>	
Vendor: Design Developers & Rehub Inc.	Vendor#:	Dept: Facilities Management	Division:
Attn: John Maka	Email: jdesigndevelopers@yahoo.com	Attn:	Email: FMAccountsPayable@dupagecounty.gov
Address: 7600 Roosevelt Rd., Ste. 166	City: Forest Park	Address: 421 N. County Farm Rd.	City: Wheaton
State: IL	Zip: 60130	State: IL	Zip: 60187
Phone: 773-510-2502	Fax:	Phone: 630-407-5700	Fax: 630-407-5701
<i>Send Payments To:</i>		<i>Ship to:</i>	
Vendor: Design Developers & Rehub Inc.	Vendor#:	Dept: Facilities Management	Division:
Attn: CR Hollins	Email: jdesigndevelopers@yahoo.com	Attn: Geoff Matteson	Email: Geoffrey.Matteson@dupagecounty.gov
Address: 7600 Roosevelt Rd., Ste. 166	City: Forest Park	Address: 102 E. Wesley St.	City: Wheaton
State: IL	Zip: 60130	State: IL	Zip: 60187
Phone: 312-560-7765	Fax:	Phone: 630-407-5681	Fax:
Shipping		Contract Dates	
Payment Terms: PER 50 ILCS 505/1	FOB: Destination	Contract Start Date (PO25): Jul 14, 2026	Contract End Date (PO25): Jul 13, 2027

Purchase Requisition Line Details

LN	Qty	UOM	Item Detail (Product #)	Description	FY	Company	AU	Acct Code	Sub-Accts/Activity Code	Unit Price	Extension
1	1	LO		Stairs Replacement	FY26	6000	1220	54010	2504520	261,000.00	261,000.00
2	1	LO		Contingency	FY26	6000	1220	54010	2504520	26,100.00	26,100.00
<i>FY is required, ensure the correct FY is selected.</i>										Requisition Total	\$ 287,100.00

<i>Comments</i>	
HEADER COMMENTS	Provide comments for P020 and P025. DuPage County Historical Museum stairs replacement, per bid #26-011-FM.
SPECIAL INSTRUCTIONS	Provide comments for Buyer or Approver (not for P020 and P025). Comments will not appear on PO. Send PO to Vendor, Cathie Figlewski, Geoff Matteson, Brian Rovik, and Clara Gomez
INTERNAL NOTES	Provide comments for department internal use (not for P020 and P025). Comments will not appear on PO. PW 7/7/26; CB 7/14/26
APPROVALS	Department Head signature approval for procurements under \$15,000. Procurement Officer Approval for ETSB.



THE COUNTY OF DUPAGE
FINANCE - PROCUREMENT
HISTORICAL MUSEUM STAIRS REPLACEMENT 26-011-FM
BID TABULATION



NO.	ITEM	UOM	QTY	Design Developers & Rehub Inc.	Manusos General Contracting, Inc.	Berglund Construction Company
				PRICE	PRICE	PRICE
1	Base Bid	LS	1	\$ 223,500.00	\$ 227,737.00	\$ 230,000.00
2	Alternate #1 - Additional Concrete Work	LS	1	\$ 9,000.00	\$ 10,725.00	\$ 20,000.00
3	Alternate #2 - Snow Melt System in Stairs	LS	1	\$ 28,500.00	\$ 59,725.00	\$ 60,000.00
GRAND TOTAL				\$ 261,000.00	\$ 298,187.00	\$ 310,000.00

NOTES
 1. Facilities Management has requested a contingency of 10%, \$261,000.00 + \$26,100.00 (contingency) = \$287,100.00.

Bid Opening 6/4/2026 @ 2:30 PM	HK, SP
Invitations Sent	70
Total Vendors Requesting Documents	3
Total Bid Responses	3

BID PRICING FORM

Section I: Contact Information

Please complete the contact information below.

BID NUMBER:	26-011-FM
COMPANY NAME:	Design Developers & Rehub Inc
CONTACT PERSON:	John Maka
CONTACT EMAIL:	jdesigndevelopers@yahoo.com

Section II: Pricing

Bidder shall provide pricing for Base Bid, Alternate #1 and Alternate #2. All goods shall be shipped F.O.B. Destination, delivered, and installed.

NO.	ITEM	UOM	QTY	PRICE
BASE BID				
1	Historical Museum Stairs Replacement	LS	1	\$ 197,000.00
2	Permit Fee Allowance	LS	1	\$4,000.00
3	Testing Allowance	LS	1	\$7,500.00
4	Construction Administration / Engineering Allowance	LS	1	\$15,000.00
GRAND TOTAL				\$ 223,500.00
GRAND TOTAL (In words)		Two hundred twenty three thousand five hundred dollars and zero cents		

NO.	ITEM	UOM	QTY	PRICE
ALTERNATE 1				
1	Additional Concrete Work [Sheet A1 – Detail C7]	LS	1	\$ 9,000.00
GRAND TOTAL (In words)		Nine thousand dollars and zero cents		



DuPage County
 Finance Department
 Procurement Division
 421 North County Farm Road
 Room 3-400
 Wheaton, Illinois 60187-3978

MANDATORY FORM

Section I: Contact Information

Complete the contact information below.

BID NUMBER:	26-011-FM
COMPANY NAME:	Design Developers & Rehub Inc
MAIN ADDRESS:	7600 Roosevelt Rd, Ste 166
CITY, STATE, ZIP CODE:	Forest Park, IL 60130
TELEPHONE NO.:	773-510-2502
BID CONTACT PERSON:	John Maka
CONTACT EMAIL:	jdesigndevelopers@yahoo.com

Section II: Contract Administration Information

Complete the contract administration information below.

CORRESPONDENCE TO CONTRACTOR:		REMIT TO CONTRACTOR:	
NAME:	Design Developers & Rehub Inc	NAME:	Design Developers & Rehub Inc
CONTACT:	John Maka	CONTACT:	CR Hollins
ADDRESS:	7600 Roosevelt Rd, Ste 166	ADDRESS:	7600 Roosevelt Rd, Ste 166
CITY, ST., ZIP:	Forest Park, IL 60130	CITY, ST., ZIP:	Forest Park, IL 60130
PHONE NO.:	773-510-2502	PHONE NO.:	312-560-7765
EMAIL:	jdesigndevelopers@yahoo.com	EMAIL:	jdesigndevelopers@yahoo.com

Section III: Certification

The undersigned certifies that they are:

- The Owner or Sole Proprietor
- A Member authorized to sign on behalf of the Partnership
- An Officer of the Corporation
- A Member of the Joint Venture

Herein after called the Bidder and that the members of the Partnership or Officers of the Corporation are as follows:

<u>John Maka</u> _____ (President or Partner) _____ (Secretary or Partner)	<u>N/A</u> _____ (Vice-President or Partner) _____ (Treasurer or Partner)
--	---

Further, the undersigned declares that the only person or parties interested in this bid as principals are those named herein; that this bid is made without collusion with any other person, firm or corporation; that he has fully examined the proposed forms of agreement and the contract specifications for the above designated purchase, all of which are on file in the office of the Procurement Officer, DuPage County, 421 North County Farm Road, Wheaton, Illinois 60187, and all other documents referred to or mentioned in the contract documents, specifications and attached exhibits, including Addenda No. N/A, and _____ issued thereto.

Further, the undersigned proposes and agrees, if this bid is accepted, to provide all necessary machinery, tools, apparatus, and other means of construction, including transportation services necessary to furnish all the materials and equipment specified or referred to in the contract documents in the manner and time and at the price therein prescribed.

Further, the undersigned certifies and warrants that they are duly authorized to execute this certification/affidavit on behalf of the Bidder and in accordance with the Partnership Agreement or by-laws of the Corporation, and the laws of the State of Illinois and that this Certification is binding upon the Bidder and is true and accurate.

Further, the undersigned certifies that the Bidder is not barred from bidding on this contract as a result of a violation of either Chapter 720 Illinois Compiled Statutes 5/33 E-3 or 5/33 E-4, bid rigging or bid-rotating, or as a result of a violation of 820 ILCS 130/1 et seq., the Illinois Prevailing Wage Act.

The undersigned certifies that they have examined and carefully prepared this bid and have checked the same in detail before submitting this bid, and that the statements contained herein are true and correct.

If a Corporation, the undersigned, further certifies that the recitals and resolutions attached hereto and made a part hereof were properly adopted by the Board of Directors of the Corporation at a meeting of said Board of Directors duly called and held and have not been repealed nor modified, and that the same remain in full force and effect. (Bidder may be requested to provide a copy of the corporate resolution granting the individual executing the contract documents authority to do so.)

Further, the Bidder certifies that it has provided equipment, supplies, or services comparable to the items specified in this contract to the parties listed in the reference section below and authorizes the County to verify references of business and credit at its option.

Finally, the Bidder, if awarded the contract, agrees to do all other things required by the contract documents, and that it will take in full payment therefore the sums set forth in the bidding schedule (subject to unit quantity adjustments based upon actual usage).

By signing below, the Bidder agrees to the terms of this Mandatory Form and certifies that the information on this form is true and correct to the best of its knowledge.

Printed Name: John Maka Signature:

Title: President Date: 6/1/2026



REQUIRED VENDOR ETHICS DISCLOSURE STATEMENT

Section I: Contact Information

Please complete the contact information below.

BID NUMBER:	26-011-FM
COMPANY NAME:	Design Developers & Rehub Inc
CONTACT PERSON:	John Maka
CONTACT EMAIL:	jdesigndevelopers@yahoo.com

Section II: Procurement Ordinance Requirements

Every contractor, union, or vendor that is seeking or has previously obtained a contract, change orders to one (1) or more contracts, or two (2) or more individual contracts with the County, shall provide to the Procurement Division a written disclosure of all political campaign contributions made by such contractor, union, or vendor to any incumbent County Board member, County Board chairman, or Countywide elected official whose office the contract to be awarded will benefit within the current and previous calendar year. The contractor, union, or vendor shall update such disclosure annually during the term of a multi-year contract and prior to any change order or renewal requiring approval by the county board. For purposes of this disclosure requirement, "contractor or vendor" includes owners, officers, managers, lobbyists, agents, consultants, bond counsel and underwriters counsel, subcontractors, and corporate entities under the control of the contracting person, and political action committees to which the contracting person has made contributions.

Has the Bidder made contributions as described above?

- Yes
 No

If "Yes", complete the required information in the table below.

RECIPIENT	DONOR	DESCRIPTION (e.g., cash, type of item, in-kind services, etc.)	AMOUNT/VALUE	DATE MADE

All contractors and vendors who have obtained or are seeking contracts with the County shall disclose the names and contact information of their lobbyists, agents and representatives and all individuals who are or will be having contact with county officers or employees in relation to the contractor bid and shall update such disclosure with any changes that may occur.

Has the Bidder had or will the Bidder have contact with lobbyists, agents, representatives or individuals who are or will be having contact with county officers or employees as described above.

Yes

No

If "Yes", list the name, phone number, and email of lobbyists, agents, representatives, and all individuals who are or will be having contact with county officers or employees in the table below.

NAME	PHONE	EMAIL

Section III: Violations

A contractor or vendor that knowingly violates these disclosure requirements is subject to penalties which may include, but are not limited to, the immediate cancellation of the contract and possible disbarment from future County contracts. Continuing and supplemental disclosure is required. The Bidder agrees to update this disclosure form as follows:

- If information changes, within five (5) days of change, or prior to county action, whichever is sooner;
- 30 days prior to the optional renewal of any contract;
- Annual disclosure for multi-year contracts on the anniversary of said contract
- With any request for change order except those issued by the county for administrative adjustments

The full text of the County's Ethics Ordinance is available at:

[Ethics | DuPage Co. IL](#)

The full text of the County's Procurement Ordinance is available at:

[ARTICLE VI. - PROCUREMENT | Code of Ordinances | DuPage County, IL | Municode Library](#)

Section IV: Certification

By signing below, the Bidder hereby acknowledges that it has received, read, and understands these requirements, and certifies that the information submitted on this form is true and correct to the best of its knowledge.

Printed Name: John Maka

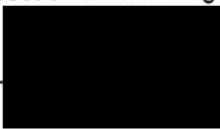
Signature: 

Title: President

Date: 6/1/2026



Public Works Requisition \$30,000.01+

421 N. COUNTY FARM
ROAD
WHEATON, IL 60187
www.dupagecounty.gov

File #: PW-P-0019-26

Agenda Date: 7/7/2026

Agenda #: 9.D.

AWARDING RESOLUTION ISSUED TO
ONE2ONE COMMUNICATIONS DBA ONESOURCE
TO PROVIDE UTILITY BILL PRINTING AND MAILING SERVICES,
FOR PUBLIC WORKS
(CONTRACT TOTAL AMOUNT \$75,000)

WHEREAS, proposals have been taken and evaluated in accordance with County Board policy; and

WHEREAS, the Public Works Committee recommends County Board approval for the issuance of a contract to ONE2ONE Communications DBA ONESOURCE, to provide Utility Bill Printing and Mailing Services, for the period of August 1, 2026 through July 31, 2030, for Public Works.

NOW, THEREFORE BE IT RESOLVED, that said contract is to provide Utility Bill Printing and Mailing Services, for the period of August 1, 2026 through July 31, 2030 for Public Works per 26-015-PW, be, and it is hereby approved for the issuance of a contract purchase order by the Procurement Division to ONE2ONE Communications DBA ONESOURCE, 900 Asbury Drive, Buffalo Grove, Illinois, 60089, for a contract total amount of \$75,000.

Enacted and approved this 14th day of July, 2026 at Wheaton, Illinois.

DEBORAH A. CONROY, CHAIR
DU PAGE COUNTY BOARD

Attest: _____

JEAN KACZMAREK, COUNTY CLERK



Procurement Review Comprehensive Checklist
 Procurement Services Division
 This form must accompany all Purchase Order Requisitions

SECTION 1: DESCRIPTION			
<i>General Tracking</i>		<i>Contract Terms</i>	
FILE ID#:	RFP, BID, QUOTE OR RENEWAL #: 26-015-PW	INITIAL TERM WITH RENEWALS: 4 YRS + 0 TERM PERIOD	INITIAL TERM TOTAL COST: \$75,000.00
COMMITTEE: PUBLIC WORKS	TARGET COMMITTEE DATE: 07/07/2026	PROMPT FOR RENEWAL:	CONTRACT TOTAL COST WITH ALL RENEWALS: \$75,000.00
	CURRENT TERM TOTAL COST: \$75,000.00	MAX LENGTH WITH ALL RENEWALS: FOUR YEARS	CURRENT TERM PERIOD: INITIAL TERM
<i>Vendor Information</i>		<i>Department Information</i>	
VENDOR: ONE2ONE Communications dba ONESOURCE	VENDOR #:	DEPT: Public Works	DEPT CONTACT NAME: Stan Spera
VENDOR CONTACT: Dave Moore	VENDOR CONTACT PHONE: 614-565-0022	DEPT CONTACT PHONE #: 630-985-7400	DEPT CONTACT EMAIL: stanley.spera@dupagecounty.gov
VENDOR CONTACT EMAIL: dave.moore@onlyonesource.com	VENDOR WEBSITE:	DEPT REQ #:	
<i>Overview</i>			
DESCRIPTION Identify scope of work, item(s) being purchased, total cost and type of procurement (i.e., lowest bid, RFP, renewal, sole source, etc.). Recommendation for the approval of a contract to ONE2ONE Communications DBA ONESOURCE, for Utility Bill Printing and Mailing Services, for Public Works, for the period of August 1, 2026, to July 31, 2030, for a total contract amount not to exceed \$75,000, per request for proposal #26-015-PW.			
JUSTIFICATION Summarize why this procurement is necessary and what objectives will be accomplished This service is needed to print and mail sewer and/or water bills and related notices to approximately 39,000 DuPage County Public Works customers on a bimonthly basis whom DuPage County provides with water and sewer services.			

SECTION 2: DECISION MEMO REQUIREMENTS	
DECISION MEMO NOT REQUIRED	Select an item from the following dropdown menu to identify why a Decision Memo (Section 3) is not required.
DECISION MEMO REQUIRED	Select an item from the following dropdown menu to identify why a Decision Memo (Section 3) is required.
RFP (REQUEST FOR PROPOSAL)	

SECTION 3: DECISION MEMO	
STRATEGIC IMPACT	Select an item from the following dropdown menu of County's strategic priorities that this action will most impact. CUSTOMER SERVICE
SOURCE SELECTION	Describe method used to select source. ONESOURCE was selected through an RFP process that included 6 responses, the results of which were reviewed by DuPage County's Procurement Officer and Public Works Department Staff after the initial selection was unable to provide the appropriate post-award documentation.
RECOMMENDATION AND TWO ALTERNATIVES	Describe staff recommendation and provide justification. Identify at least 2 other options to accomplish this request, including status quo, (i.e., take no action). 1. Approve contract with ONESOURCE, for a contract total not to exceed \$75,000. 2. Do not approve the contract and go back out to bid. Not recommended due to the pricing and time required to implement a new system before the current agreement expires. 3. Do not award and complete work in house. Not recommended due to the number of bills and lack of capabilities by Public Works Staff.

SECTION 4: SOLE SOURCE MEMO/JUSTIFICATION

JUSTIFICATION	Select an item from the following dropdown menu to justify why this is a sole source procurement.
NECESSITY AND UNIQUE FEATURES	Describe the product or services that are not available from other vendors. Explain necessary and unique features or services. Attach letters from manufacturer, letters from distributor, warranties, licenses, or patents as needed. Be specific.
MARKET TESTING	List and describe the last time the market has been tested on the applicability of the sole source. If it has not been tested over the last 12 months, explain why not.
AVAILABILITY	Describe steps taken to verify that these features are not available elsewhere. Included a detailed list of all products or services by brand/manufacturer examined and include names, phone numbers, and emails of people contacted.

SECTION 5: Purchase Requisition Information

<i>Send Purchase Order To:</i>		<i>Send Invoices To:</i>	
Vendor: ONE2ONE Communications dba ONESOURCE	Vendor#:	Dept: Public Works	Division: Public Works
Attn: Dave Moore	Email: dave.moore@onlyonesource.com	Attn: Magda Leonida-Padilla	Email: pwaccountspayable@dupagecount y.gov
Address: 900 Asbury Drive	City: Buffalo Grove	Address: 7900 S. Rt. 53	City: Woodridge
State: IL	Zip: 60089	State: IL	Zip: 60517
Phone: 614-565-0022	Fax:	Phone: 630-985-7400	Fax:
<i>Send Payments To:</i>		<i>Ship to:</i>	
Vendor: Same as above	Vendor#: Same as above	Dept: Same as above	Division: Same as above
Attn:	Email:	Attn:	Email:
Address:	City:	Address:	City:
State:	Zip:	State:	Zip:
Phone:	Fax:	Phone:	Fax:
Shipping		Contract Dates	
Payment Terms: PER 50 ILCS 505/1	FOB: Destination	Contract Start Date (PO25): Aug 1, 2026	Contract End Date (PO25): 7/31/2030
Contract Administrator (PO25): Drew Cormican			

Purchase Requisition Line Details

LN	Qty	UOM	Item Detail (Product #)	Description	FY	Company	AU	Acct Code	Sub-Accts/Activity Code	Unit Price	Extension
1	1	EA		Printing and direct mail services	FY26	2000	2665	53800		10,000.00	10,000.00
2	1	EA		Printing and direct mail services	FY27	2000	2665	53800		20,000.00	20,000.00
3	1	EA		Printing and direct mail services	FY28	2000	2665	53800		20,000.00	20,000.00
4	1	EA		Printing and direct mail services	FY29	2000	2665	53800		20,000.00	20,000.00
5	1	EA		Printing and direct mail services	FY30	2000	2665	53800		5,000.00	5,000.00
<i>FY is required, assure the correct FY is selected.</i>										Requisition Total	\$ 75,000.00

<i>Comments</i>	
HEADER COMMENTS	Provide comments for P020 and P025.
SPECIAL INSTRUCTIONS	Provide comments for Buyer or Approver (not for P020 and P025). Comments will not appear on PO.
INTERNAL NOTES	Provide comments for department internal use (not for P020 and P025). Comments will not appear on PO.
APPROVALS	Department Head signature approval for procurements under \$15,000. Procurement Officer Approval for ETSB.

The following documents have been attached: W-9 Vendor Ethics Disclosure Statement

PROPOSAL PRICING FORM

Section I: Contact Information

Please complete the contact information below.

BID NUMBER:	26-015-PW
COMPANY NAME:	ONE2ONE COMMUNICATIONS dba ONESOURCE
CONTACT PERSON:	DAVE MOORE
CONTACT EMAIL:	dave.moore@onlyonesource.com

Section II: Pricing

The quantities provided are estimated for a one-year period.

NO.	ITEM	UOM	QTY	PRICE	EXTENDED PRICE
1	Utility Bill statements – printing and laser imaging	EA	162,000	\$ 0.025	\$ 4,050.00
2	Utility Bill statements – #10 mailing envelopes	EA	162,000	\$ 0.018	\$ 2,916.00
3	Utility Bill statements – #9 business reply envelopes	EA	162,000	\$ 0.016	\$ 2,592.00
4	Utility Bill statements – Folding, insertion and mailing services	EA	162,000	\$ 0.029	\$ 4,698.00
5	Utility Bill statements – Initial design, set-up, artwork costs (only applies to year 1)	EA	1	\$ N/C	\$ 0
6	Past Due notices – printing and laser imaging	EA	22,800	\$ 0.028	\$ 638.40
7	Past Due notices – #10 mailing envelopes	EA	22,800	\$ 0.018	\$ 410.40
8	Past Due notices – #9 business reply envelopes	EA	22,800	\$ 0.016	\$ 364.80
9	Past Due notices – Folding, insertion and mailing services	EA	22,800	\$ 0.029	\$ 661.20
10	Past Due notices – Initial design, set-up, artwork costs (only applies to year 1)	EA	1	\$ N/C	\$ 0
11	Disconnect notices – printing and laser imaging	EA	12,000	\$ 0.028	\$ 336.00
12	Disconnect notices – #10 mailing envelopes	EA	12,000	\$ 0.018	\$ 216.00
13	Disconnect notices – Folding, insertion and mailing services	EA	12,000	\$ 0.029	\$ 348.00
14	Disconnect notices – Initial design, set-up, artwork costs (only applies to year 1)	EA	1	\$ N/C	\$
GRAND TOTAL (One Year Total Cost)					\$ 17,230.80

Section III: Price Adjustment

Pricing shall be maintained for the initial one (1) year period. Price adjustments for years two (2) through four (4) shall be provided by Bidder at the time of bid submission.

Price Adjustment – Year 2 CPI Index, 3% maximum _____ %

Price Adjustment – Year 3 CPI Index, 3% maximum _____ %

Price Adjustment – Year 4 CPI Index, 3% maximum _____ %

Section IV: Certification

By signing below, the Bidder agrees to provide the required goods and/or services described in the Bid Specifications for the prices quoted on this Proposal Pricing Form.

Printed Name: David Moore _____ Signature  _____

Title: Senior Vice President Sales _____ Date: 03/17/2026 _____

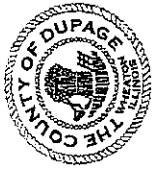

THE COUNTY OF DUPAGE
FINANCE - PROCUREMENT
UTILITY BILL PRINTING AND MAILING SERVICES 26-015-PW
BID TABULATION

Criteria	Available Points	Lineage Mailing Services LLC dba Strahm, Lineage Connect	One2One Communications, LLC dba OneSource	Sebis Direct, Inc.	The Master Touch, LLC	Wolverine Mailing Packaging Whse Inc dba Wolverine Solutions Group
Firm Qualifications	20	17	18	19	17	19
Key Qualifications	20	17	17	19	17	18
Project Understanding	20	17	17	18	16	18
Price	40	33	40	30	30	24
Total	100	84	92	86	80	79

Fee and Rate Proposal for Years 1-4	\$	86,694.56	\$	72,087.00	\$	95,724.61	\$	96,931.20	\$	118,526.34
Percentage of points		83%		100%		75%		74%		61%
Points awarded (wtd against lowest price)		33		40		30		30		24

NOTES

1. Peregrine Services, Inc. has been deemed nonresponsible for failure to provide required post-award documentation.

RFP Posted on 2/27/2026	SR, HK
Bid Opened On 3/18/2026, 2:30 PM by	
Invitations Sent	18
Total Requesting Documents	7
Total Bid Responses Received	6

Further, the undersigned certifies and warrants that they are duly authorized to execute this certification/affidavit on behalf of the Offeror and in accordance with the Partnership Agreement or by-laws of the Corporation, and the laws of the State of Illinois and that this Certification is binding upon the Offeror and is true and accurate.

Further, the undersigned certifies that the Offeror is not barred from proposing on this contract as a result of a violation of either 720 Illinois Compiled Statutes 5/33 E-3 or 5/33 E-4, Proposal rigging or Proposal-rotating, or as a result of a violation of 820 ILCS 130/1 et seq., the Illinois Prevailing Wage Act.

The undersigned certifies that they have examined and carefully prepared this Proposal and have checked the same in detail before submitting this Proposal, and that the statements contained herein are true and correct.

If a Corporation, the undersigned, further certifies that the recitals and resolutions attached hereto and made a part hereof were properly adopted by the Board of Directors of the Corporation at a meeting of said Board of Directors duly called and held and have not been repealed nor modified, and that the same remain in full force and effect. (Offeror may be requested to provide a copy of the corporate resolution granting the individual executing the contract documents authority to do so.)

Further, the Offeror certifies that they have provided equipment, supplies, or services comparable to the items specified in this contract to the parties listed in the reference section below and authorizes the County to verify references of business and credit at its option.

Finally, the Offeror, if awarded the contract, agrees to do all other things required by the contract documents, and that it will take in full payment therefore the sums set forth in the cost schedule.

PROPOSAL AWARD CRITERIA

The Offeror acknowledges and agrees that the proposal will be awarded to the most responsive, responsible vendor meeting specifications based upon the highest score compiled during evaluation of the proposals outlined in the selection process.

The Offeror agrees to provide the service described in this solicitation and in the contract specifications under the conditions outlined in attached documents for the amount stated.

By signing below, the Offeror agrees to the terms of this Proposal Form and certifies that the information submitted on this form is true and correct to the best of its knowledge.

Offeror: David Moore

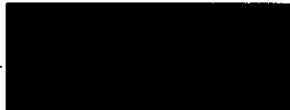
Signature: 

Title: Senior Vice President

Date: 03/17/2026



DuPage County
 Finance Department
 Procurement Division
 421 North County Farm Road
 Room 3-400
 Wheaton, Illinois 60187-3978

REQUIRED VENDOR ETHICS DISCLOSURE STATEMENT

Section I: Contact Information

Please complete the contact information below.

BID NUMBER:	26-015-PW
COMPANY NAME:	ONE2ONE COMMUNICATIONS dba ONESOURCE
CONTACT PERSON:	DAVE MOORE
CONTACT EMAIL:	dave.moore@onlyonesource.com

Section II: Procurement Ordinance Requirements

Every contractor, union, or vendor that is seeking or has previously obtained a contract, change orders to one (1) or more contracts, or two (2) or more individual contracts with the County, shall provide to the Procurement Division a written disclosure of all political campaign contributions made by such contractor, union, or vendor to any incumbent County Board member, County Board chairman, or Countywide elected official whose office the contract to be awarded will benefit within the current and previous calendar year. The contractor, union, or vendor shall update such disclosure annually during the term of a multi-year contract and prior to any change order or renewal requiring approval by the county board. For purposes of this disclosure requirement, "contractor or vendor" includes owners, officers, managers, lobbyists, agents, consultants, bond counsel and underwriters counsel, subcontractors, and corporate entities under the control of the contracting person, and political action committees to which the contracting person has made contributions.

Has the Bidder made contributions as described above?

Yes

No

If "Yes", complete the required information in the table below.

RECIPIENT	DONOR	DESCRIPTION (e.g., cash, type of item, in-kind services, etc.)	AMOUNT/VALUE	DATE MADE

All contractors and vendors who have obtained or are seeking contracts with the County shall disclose the names and contact information of their lobbyists, agents and representatives and all individuals who are or will be having contact with county officers or employees in relation to the contractor bid and shall update such disclosure with any changes that may occur.

Has the Bidder had or will the Bidder have contact with lobbyists, agents, representatives or individuals who are or will be having contact with county officers or employees as described above.

Yes

No

If "Yes", list the name, phone number, and email of lobbyists, agents, representatives, and all individuals who are or will be having contact with county officers or employees in the table below.

NAME	PHONE	EMAIL

Section III: Violations

A contractor or vendor that knowingly violates these disclosure requirements is subject to penalties which may include, but are not limited to, the immediate cancellation of the contract and possible disbarment from future County contracts. Continuing and supplemental disclosure is required. The Bidder agrees to update this disclosure form as follows:

- If information changes, within five (5) days of change, or prior to county action, whichever is sooner;
- 30 days prior to the optional renewal of any contract;
- Annual disclosure for multi-year contracts on the anniversary of said contract
- With any request for change order except those issued by the county for administrative adjustments

The full text of the County's Ethics Ordinance is available at:

[Ethics | DuPage Co, IL](#)

The full text of the County's Procurement Ordinance is available at:

[ARTICLE VI. - PROCUREMENT | Code of Ordinances | DuPage County, IL | Municode Library](#)

Section IV: Certification

By signing below, the Bidder hereby acknowledges that it has received, read, and understands these requirements, and certifies that the information submitted on this form is true and correct to the best of its knowledge.

Printed Name: David Moore

Signature: 

Title: Senior Vice President of Sales

Date: 06/22/2026



Public Works Resolution

421 N. COUNTY FARM
ROAD
WHEATON, IL 60187
www.dupagecounty.gov

File #: PW-R-0006-26

Agenda Date: 7/7/2026

Agenda #: 10.A.

RESOLUTION TO RESCIND PW-P-0015-26
ISSUED TO PEREGRINE SERVICES, INC.
TO PROVIDE UTILITY BILL PRINTING AND MAILING SERVICES
FOR PUBLIC WORKS
(CONTRACT TOTAL NOT TO EXCEED \$88,300.80)

WHEREAS, on May 26, 2026, the DuPage County Board approved PW-P-0015-26 for a contract purchase order to Peregrine Services, Inc., to provide Utility Bill Printing and Mailing Services, for Public Works, for the four-year period, August 1, 2026, through July 31, 2030, for Public Works; and

WHEREAS, the awarded vendor is unable to meet all of the qualifications on the original bid #26-015-PW.

NOW, THEREFORE, BE IT RESOLVED, by the DuPage County Board that Resolution PW-P-0015-26, dated May 26th, 2026, shall be and is hereby repealed and rescinded in its entirety effective immediately.

Enacted and approved this 14th day of July, 2026 at Wheaton, Illinois.

DEBORAH A. CONROY, CHAIR
DU PAGE COUNTY BOARD

Attest: _____

JEAN KACZMAREK, COUNTY CLERK



Informational

421 N. COUNTY FARM
ROAD
WHEATON, IL 60187
www.dupagecounty.gov

File #: 26-1918

Agenda Date: 7/7/2026

Agenda #: 11.A.
